

REVISION HISTORY			
REV	DATE	BY	DESCRIPTION
D	22JAN2019	CBI/DMS	PRN: P2019-0167

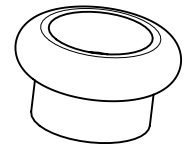
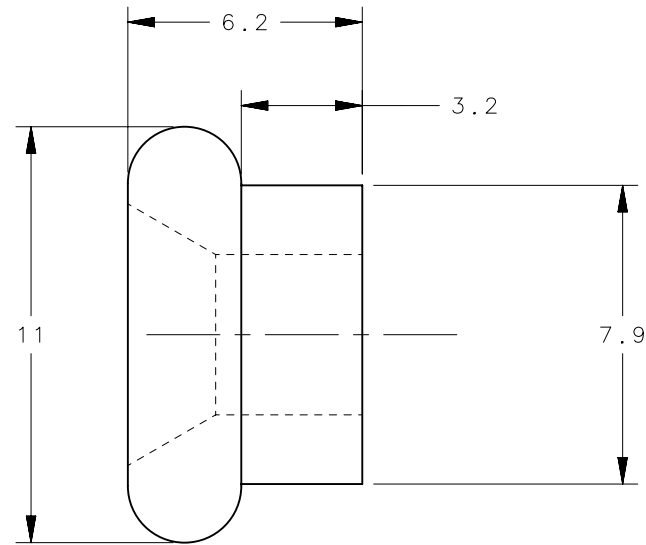
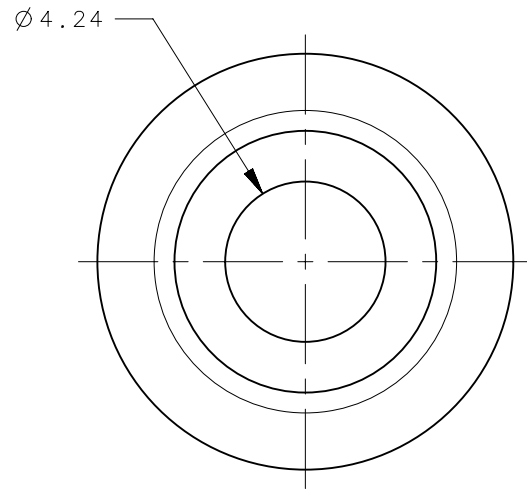

SCALE 2:1

97-57-105-52	KEEPER	STAINLESS STEEL	SEE NOTE D
97-57-105-24	KEEPER	STAINLESS STEEL	PASSIVATED
97-57-105-15	KEEPER	STEEL	SEE NOTE B
97-57-105-11	KEEPER	STEEL	SEE NOTE A
PART NUMBER	TYPE OF COMPONENT	MATERIAL	FINISH

THIRD ANGLE PROJECTION		 CONNECT • CREATE • INNOVATE	
MILLIMETERS [IN]			
TOLERANCES UNLESS OTHERWISE NOTED		DESCRIPTION	
ALL DIMENSIONS WITHOUT TOLERANCES ARE FOR REFERENCE ONLY.		BUTTON KEEPER	
PROPRIETARY ITEM <small>EXCEPT FOR USES EXPRESSLY GRANTED IN WRITING, INFORMATION DISCLOSED HEREON IS CONFIDENTIAL AND ALL RIGHTS, PATENT AND OTHERWISE, ARE RESERVED BY SOUTHCO, INC.</small>	PER ASME Y14.5M-1994	SIZE A4	SYSTEM NX
		DWG NO. J-97-57-105	
		DRAWN BY RJB	DATE 27JAN1997
		SCALE 5:1	SHEET 1 OF 1

NOTES:

- A- ZINC PLATE CHROMATE, PLUS SEALER.
- B- HEAT TREATED, BLACK ORGANIC COATING.
- C- HEAT TREATED, PHOSPHATE DIP, SILVER POWDER COAT.
- D- BLACK POWDER COAT.
- E- PHOSPHATE DIP, SILVER POWDER COAT.