

Southco

PROPRIETARY ITEM - EXCEPT FOR USES EXPRESSLY GRANTED IN WRITING INFORMATION DISCLOSED HEREIN, ALL RIGHTS IN THIS PATENT AND OTHERS ARE RESERVED BY SOUTHCO, INC.

**VISE-ACTION™ LATCH
7mm SQUARE DRIVER**

DATE: 5/26/89
DRAWN (CHKD) RES: [blank]
SCALE: 0.75 : 1

DRAWING NUMBER: J-E3-34

REV.	DATE	DRAWN	REVISION
B	15 JAN 93	KPL	PRN : S-1-O-3
C	09 OCT 96	BWD	PRN : S-9-3-2-3
D	03 DEC 98	JGK	PRN : E3-7-1-6A
E	07 JUL 99	SCK	PRN : E3-801/E3-806
F	14 FEB 2001	JRS	PRN : E3-847A
G	29 JAN 2015	CMS	PRN : P2015-0226
H	30 JUN 2021	CMS	PRN : P2021-1293

ASSEMBLY PART NO.	GRIP RANGE	PAWL OFFSET
E3-34-1X	0.37 - 0.83 or 2.37 - 3.08 or	1.08
E3-34-2X	0.85 - 2.52 or	0.54
E3-34-3X	1.39 - 2.00	NONE

THE ABOVE PART NUMBERS ARE TYPE "A" (TURN COUNTERCLOCKWISE TO LATCH). FOR TYPE "B" ASSEMBLIES (TURN COUNTERCLOCKWISE TO LATCH), CHANGE THE THIRD DIGIT OF THE PART NUMBER FROM 3 TO 2.
EXAMPLE: E3-234-15

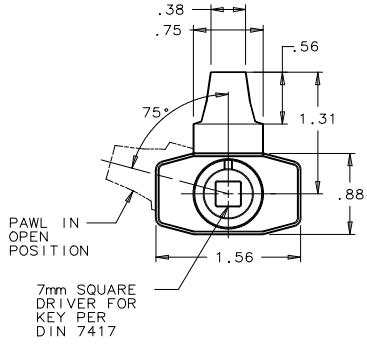

7mm SQUARE DRIVER FOR KEY PER DIN 7417

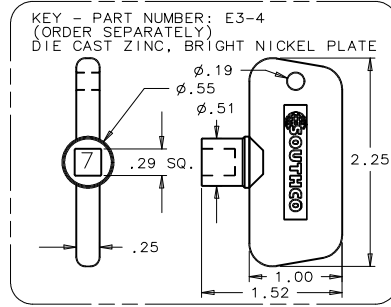
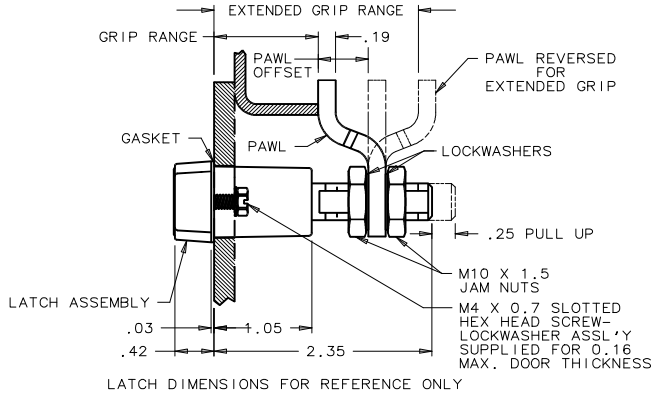

NOTES:

- OPERATION: 195° TURN OF KEY CAUSES PAWL TO ROTATE 75° THEN PULL UP 0.25.
- PAWL, NUTS, LOCKWASHERS, GASKET, AND SCREW ASSLY'S SHIPPED UNASSEMBLED IN BAG WITH LATCH ASSEMBLY.
- INSTALLATION:
 - INSTALL GASKET OVER LATCH AND INSTALL LATCH IN DOOR. ATTACH USING M4 SCREW ASSEMBLIES (7mm HEX) 15 in-lb MAX. TIGHTENING TORQUE.
 - INSTALL JAM NUT, LOCKWASHER, PAWL, LOCKWASHER, AND JAM NUT ON SHAFT. ADJUST JAM NUTS TO POSITION PAWL AT CORRECT GRIP (WITH LATCH CLOSED). TIGHTEN JAM NUTS (180 in-lb MAX. TORQUE) USING TWO 17mm WRENCHES.

CAUTION: ADJUST PAWL SO THAT NO MORE THAN 70 in-lb TORQUE ON KEY IS REQUIRED TO CLOSE LATCH.

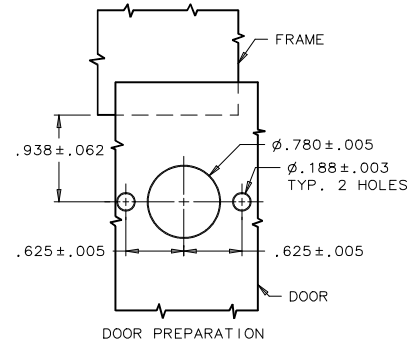

X- FINISH

- 1 - BRIGHT CHROME PLATE
- 4 - CARDINAL WHITE POWDER COAT
- 1 - BLACK POWDER COAT
- 1 - SATIN SILVER POLYESTER POWDER COAT

NOTE A: ZINC PLATE CHROMATE PLUS SEALER

DRAWING NUMBER
J-E3-34

† TM - METAL COATINGS INTERNATIONAL, INC.

PATENT US, UK
DIMENSIONS ARE INCHES UNLESS NOTED OTHERWISE