

REVISION HISTORY			
REV	DATE	BY	DESCRIPTION
C	10AUG2021	SAK/MBT	PRN: P2021-1598

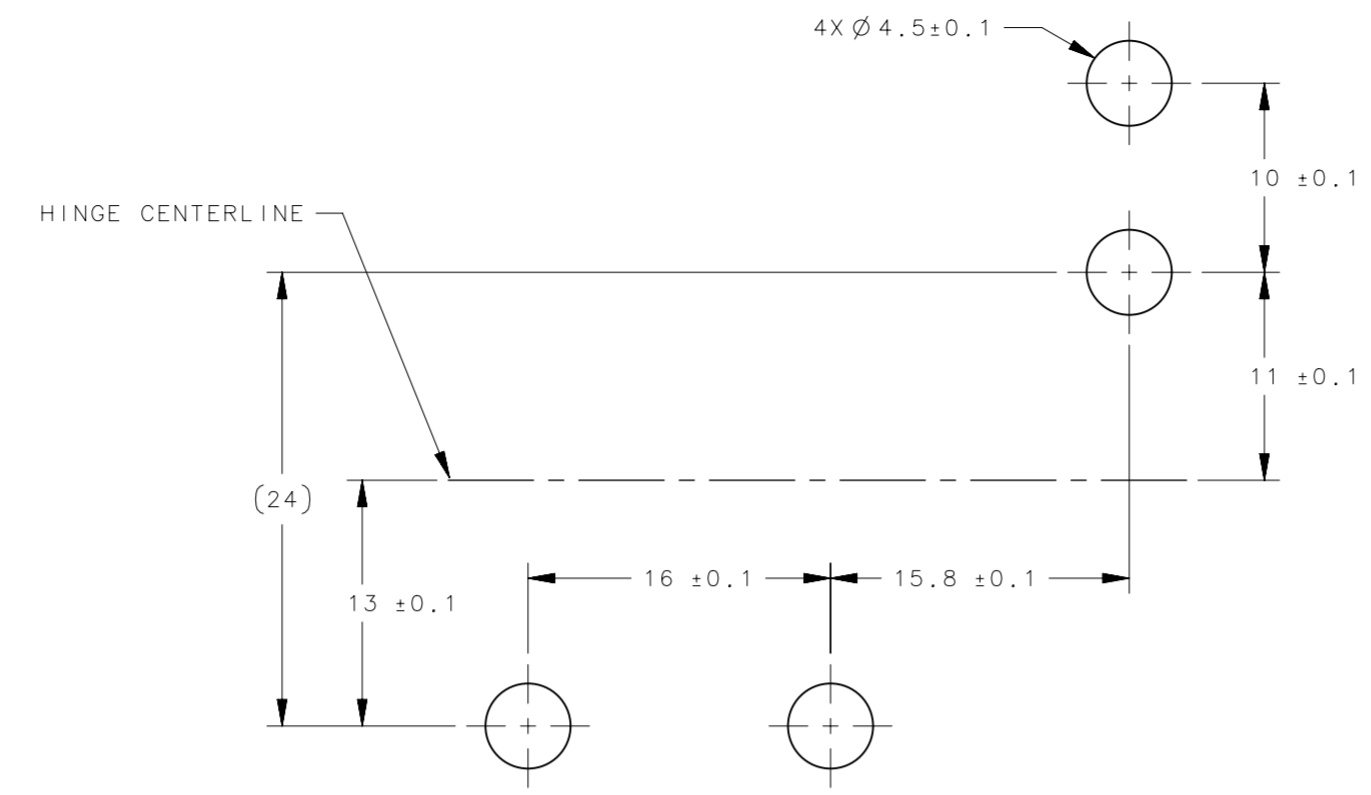

PANEL PREPARATION

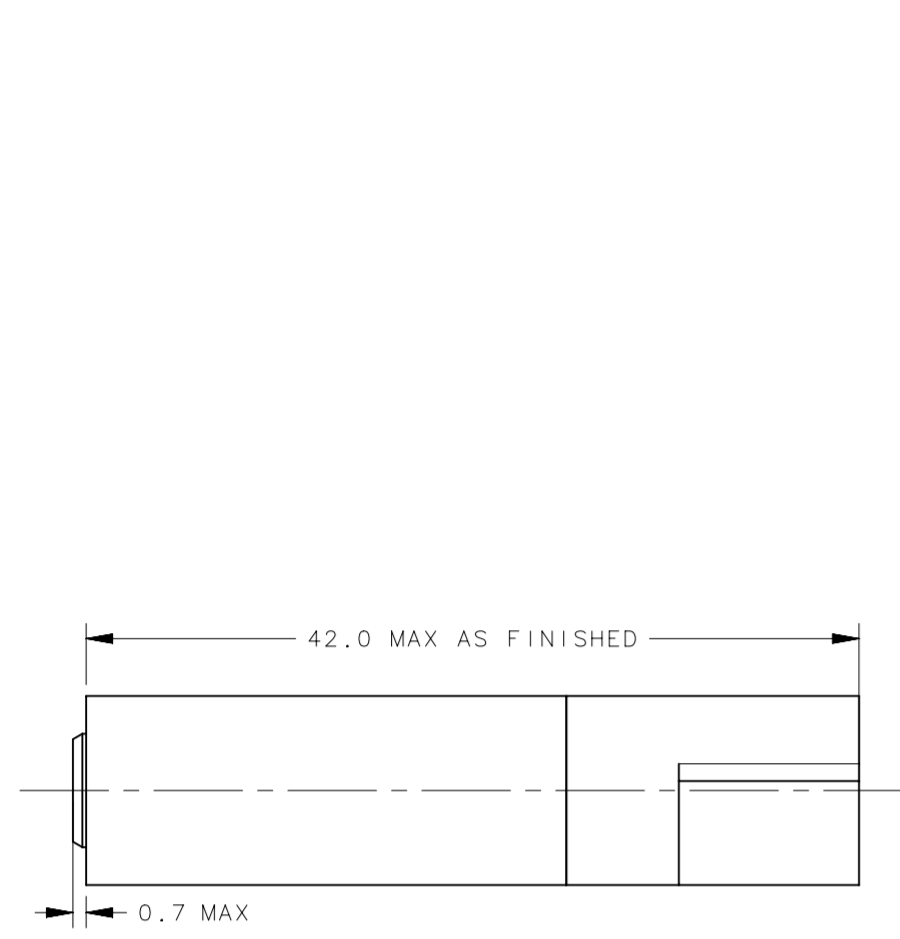
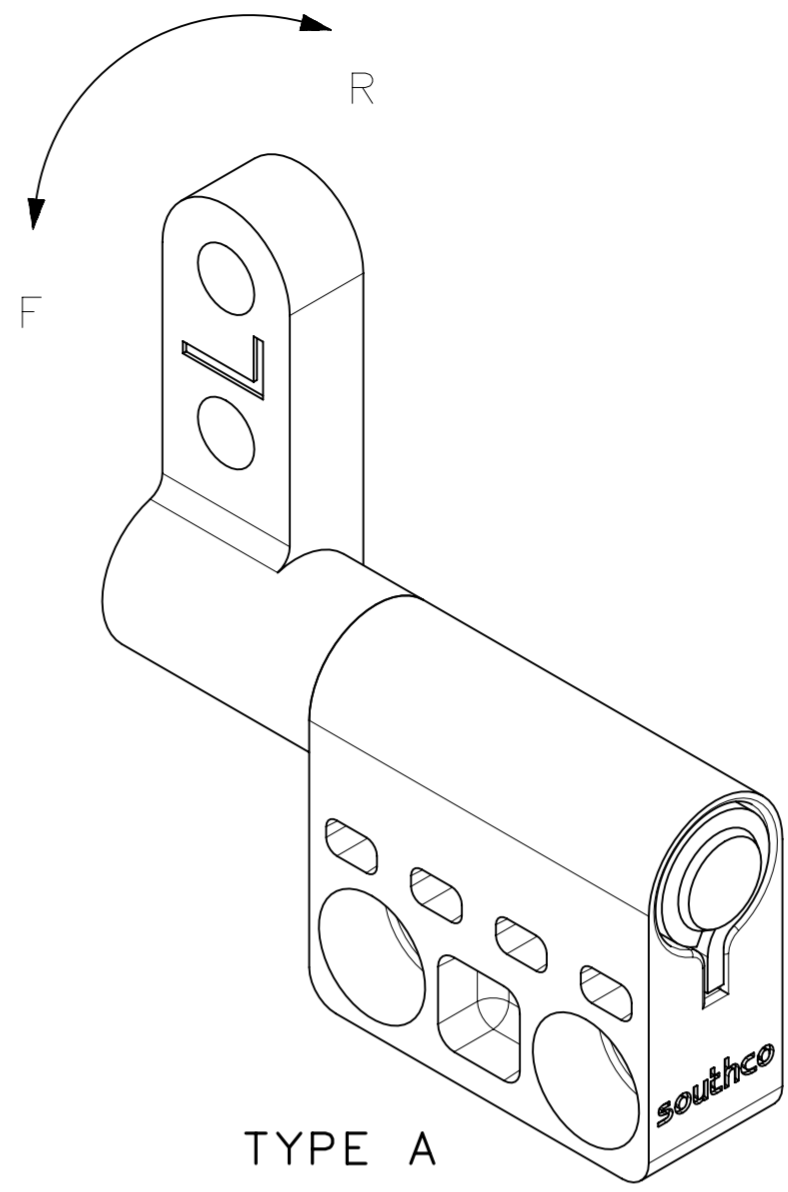
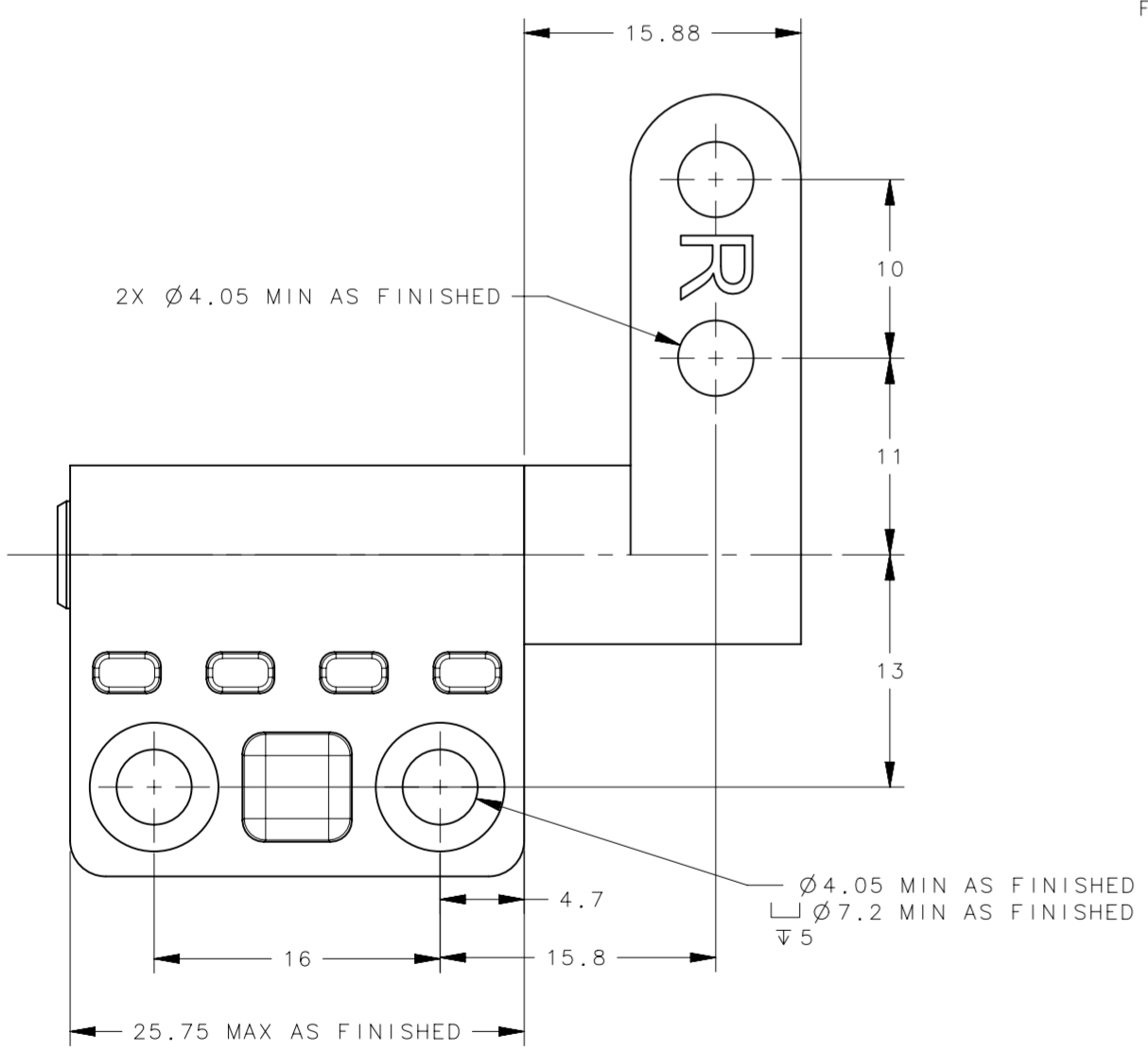
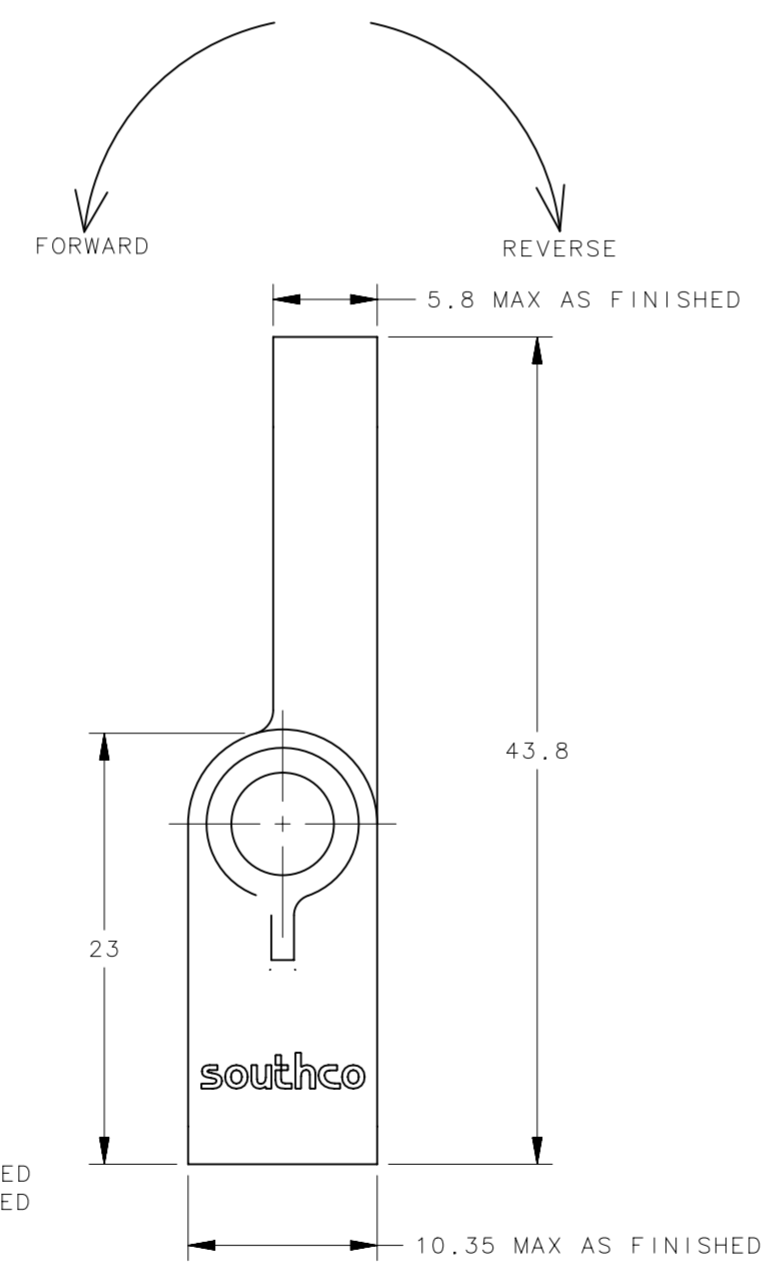

TYPE A

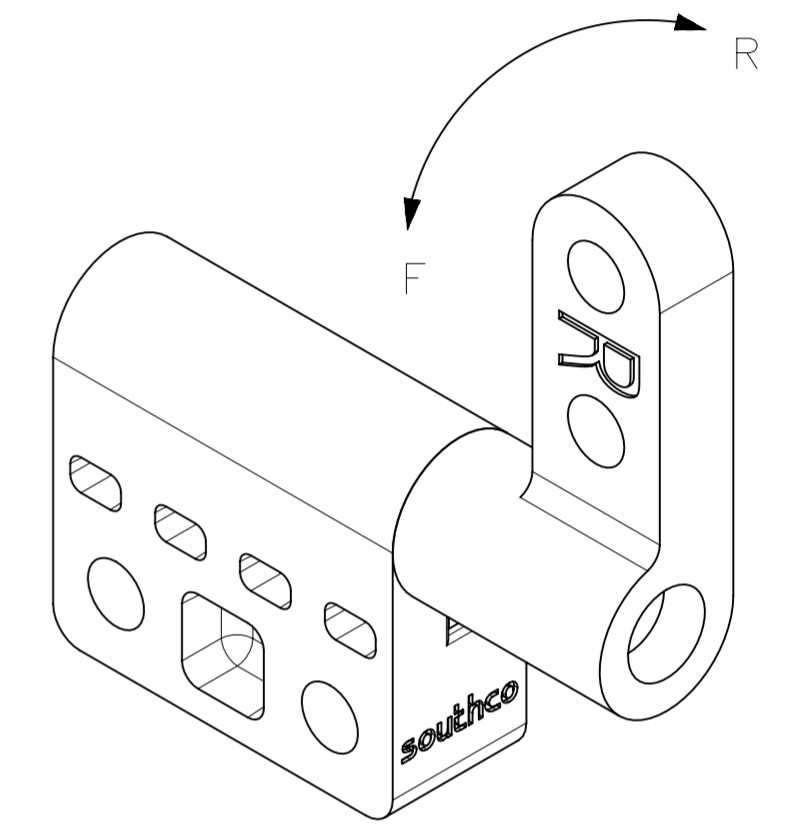

**TYPE B
(SHOWN DIMENSIONED)**

PART NUMBER		STATIC TORQUE ± 20%	
TYPE A	TYPE B	FORWARD (IN-LBF)	REVERSE (IN-LBF)
ST-10A-80SA-XX	ST-10A-80SB-XX	8	8
ST-10A-120SA-XX	ST-10A-120SB-XX	12	12
ST-10A-120FA-XX	ST-10A-120FB-XX	12	7.2 REF
ST-10A-120RA-XX	ST-10A-120RB-XX	7.2 REF	12

- NOTES:
- MATERIAL AND FINISH:
HOUSING AND ADAPTER - ZINC ALLOY. FOR FINISH SEE TABLE
SHAFT AND TORQUE ELEMENTS - HARDENED STEEL
 - INSTALL HINGE USING A No. 8 OR M4 SOCKET HEAD CAP SCREW.
 - FOR PROPER FUNCTION, ASSEMBLY MUST INCLUDE (1) TYPE "A" & (1) TYPE "B" HINGE.
 - DIMENSIONS INDICATE AS-BUILT CONDITION, LEAF TO LEAF SPACING WILL SELF ADJUST DURING OPERATION.
 - PERFORMANCE TORQUE TOLERANCE OVER 20,000 CYCLES.

ST-10A-XXXX-50	ASSEMBLY - COATED	BLACK POWDER COAT
ST-10A-XXXX-33	ASSEMBLY - AS CAST	NATURAL FINISH
PART NUMBER	TYPE OF COMPONENT	
THIRD ANGLE PROJECTION		
MILLIMETERS [IN]		
TOLERANCES UNLESS OTHERWISE NOTED		
ALL DIMENSIONS ARE IN MILLIMETERS ALL DIMENSIONS WITHOUT TOLERANCES ARE FOR REFERENCE ONLY		
PROPRIETARY ITEM EXCEPT FOR USES EXPRESSLY GRANTED IN WRITING. INFORMATION DISCLOSED HEREON IS CONFIDENTIAL AND ALL RIGHTS, PATENT AND OTHERWISE, ARE RESERVED BY SOUTHCO, INC.	PER ASME Y14.5M-1994	DESCRIPTION: ST-10A HINGE ASSEMBLY
SIZE: A2	SYSTEM: NX	DWG NO.: J-ST-10A-1
DRAWN BY: JJT/MJS	DATE: 06JUL2017	SCALE: 2:1 SHEET 1 OF 1