

REV	DATE	DRAWN/CHKD	DESCRIPTION						

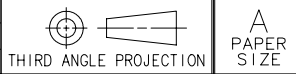

SOUTHCO PERFORMANCE GUIDELINES

THE PERFORMANCE GUIDELINES SHOWN ON THIS PAGE ARE SUPPLIED AS A GENERAL GUIDE ONLY, AS CONDITIONS VARY WITH EACH APPLICATION AND METHOD OF INSTALLATION. STRENGTH DATA GIVEN IS FOR FAILURE OF THE PRODUCT OR FOR SUFFICIENT DEFORMATION TO MAKE PRODUCT INOPERABLE. NO SAFETY FACTOR HAS BEEN APPLIED IT IS RECOMMENDED THAT THE USER REQUEST A PRODUCT SAMPLE FOR TESTING TO DETERMINE THE SUITABILITY OF THE PRODUCT FOR THE PURPOSE INTENDED AND USER'S PARTICULAR APPLICATION.

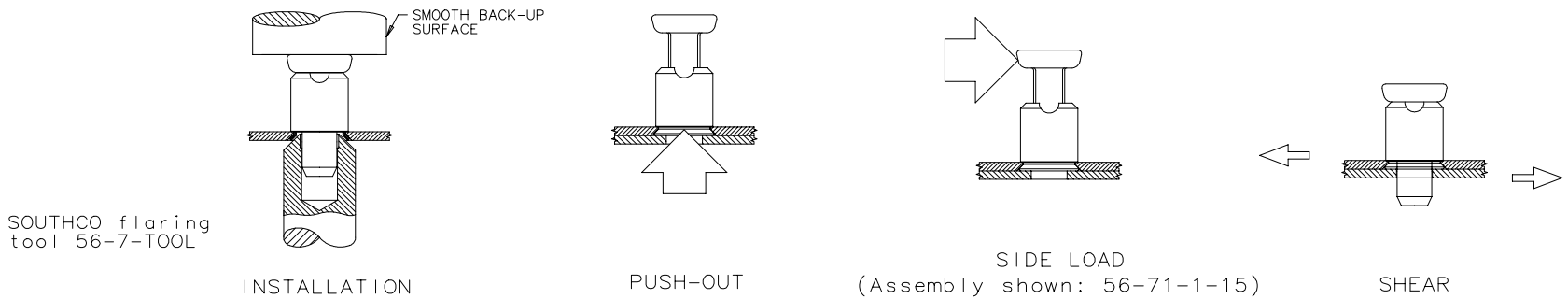

ASSEMBLY PART NUMBERS	PANEL MATERIAL	OPTIMUM INSTALLATION FORCE		MINIMUM PUSH-OUT FORCE HELD			MINIMUM SIDE FORCE HELD			MINIMUM ULTIMATE SHEAR LOAD		
		N	lbf.	N	lbf.	Failure Mode	N	lbf.	Failure Mode	N	lbf.	Failure Mode
56-7X-X-15	(1)	2,500	562	1,025	230	A	300	67	A	7,800	1,753	B

Salt Spray Test Data: Parts passed 500 hours of salt spray testing exposure per ASTM B-117. No visual rust observed; no loss of function.

1. Assemblies were installed and tested in 1.6mm (.060 inches) thick ASTM A109 TEMPER 2 Steel panels (55-70 HRB).

FAILURE MODES OBSERVED IN TESTING

- A. Sample released from panel.
- B. Ferrule deformed.