

REV.	DATE	BY-CHKD	REVISIONS	ITEM	COMPONENT	PART No.	MATERIAL	FINISH
B	05 MAY 94	BMC	PRN: 19-92	ASSEMBLY		19-14-10		
C	04 JAN 95	JGK	PRN: 19-113					
D	05 MAY 95	MMM	PRN: 19-122		HANDLE		DIE CAST ZINC	SEE NOTE "B"
E	09 OCT 96	SWD	PRN: S-93-23		SHAFT		BRASS	SEE NOTE "C"
F	02 JAN 2002	DLH	PRN: P2002-0764		PIN		303 STAINLESS STEEL	SEE NOTE "A"
G	17 AUG 2016	JPK CMS	PRN: P2016-1906		BUSHING		IR/BR RUBBER	BLACK
					NUT		NYLON	BLACK
					WASHER		ACETAL	BLACK

INSTALLATION INSTRUCTIONS:

- PREPARE A SHAPED HOLE IN DOOR OR OUTER PANEL AND A ROUND HOLE IN THE FRAME.
- WITH HANDLE IN OPEN POSITION INSERT SHAFT THROUGH HOLE IN DOOR, THEN PASS BUSHING OVER SHAFT AND SECURE WITH NYLON NUT.
- ADJUST NYLON NUT TO PROVIDE A SATISFACTORY HOLD IN, OR BEHIND FRAME HOLE WITH MODERATE LOCKING FORCE.

NOTE A: BLACK OXIDE COATING.
 NOTE B: BLACK POWDER COATING.
 NOTE C: ZINC PLATE, BLACK CHROMATE

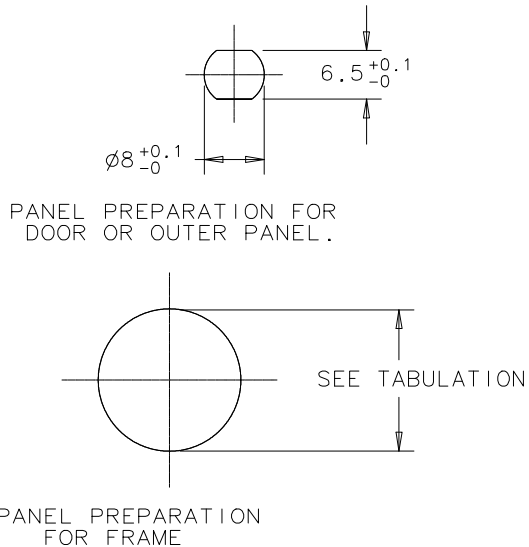

RECOMMENDED FRAME HOLE DIAMETERS

FRAME THICKNESS	HOLE DIAMETER
1.2 TO 3.2	19 $^{+0.5}_{-0.0}$
3.2 TO 4.8	19.5 $^{+0.5}_{-0.0}$
4.8 TO 6.4	20 $^{+0.5}_{-0.0}$
6.4 AND UP	20.5 $^{+0.5}_{-0.0}$

