

REVISION HISTORY			
REV	DATE	BY	DESCRIPTION
F	06NOV2019	DKP/DMS	PRN: P2019-2756

PART NUMBER: **E5-4-WW3-YY1**

ACTUATION STYLE (SEE BELOW) SEE NOTE 3 CAM TYPE (SEE GRIP TABLE)

WW ACTUATION STYLES:

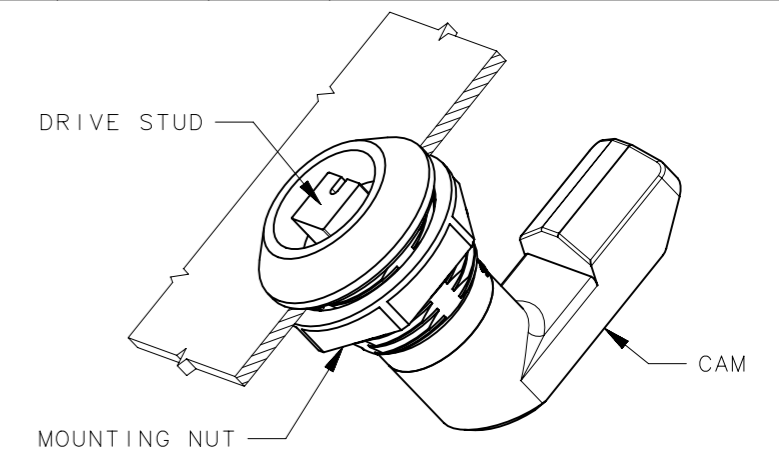
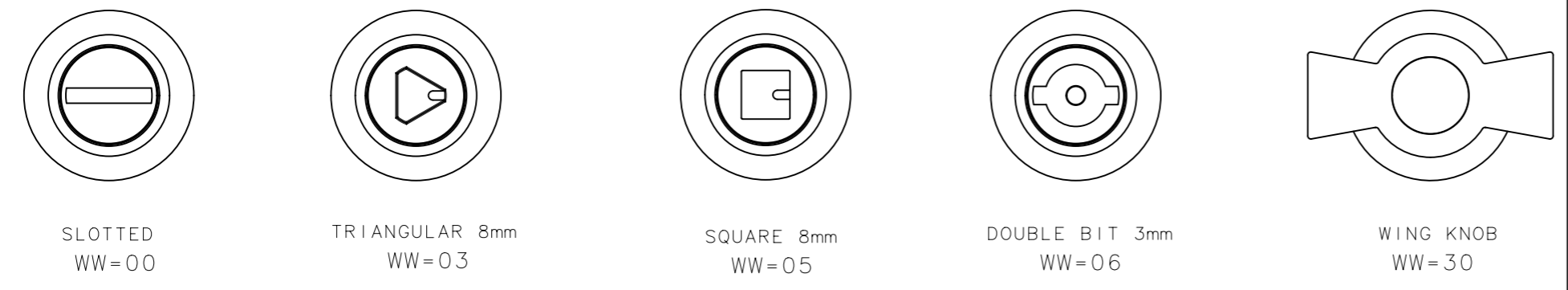

CAM STYLE "YY"	GRIP ±1.0 (mm)	L	CAM PART NUMBER (SEE NOTE 4)	MAXIMUM DOOR THICKNESS FOR ASSEMBLED LATCH					
				1mm	2mm	3mm	4mm	5mm	6mm
16	16	28.6	E5-3516	✓	✓	✓	✓	✓	✓
18	18	28.6	E5-3518	✓	✓	✓	✓	✓	✓
20	20	28.6	E5-3520	✓	✓	✓	✓	✓	✓
22	22	32.6	E5-3522	✓	✓	✓	✓	✓	✓
24	24	34.6	E5-3524	✓	✓	✓	✓	✓	✓
25	25	35.6	E5-3525	✓	✓	✓	✓	✓	✓
26	26	36.6	E5-3526	✓	✓	✓	✓	✓	✓
28	28	38.6	E5-3528	✓	✓	✓	✓	✓	✓
30	30	40.6	E5-3530	✓	✓	✓	✓	✓	✓
32	32	42.6	E5-3532	✓	✓	✓	✓	✓	✓
34	34	44.6	E5-3534	✓	✓	✓	✓	✓	✓
36	36	46.6	E5-3536	✓	✓	✓	✓	✓	✓
UU			NO CAM						

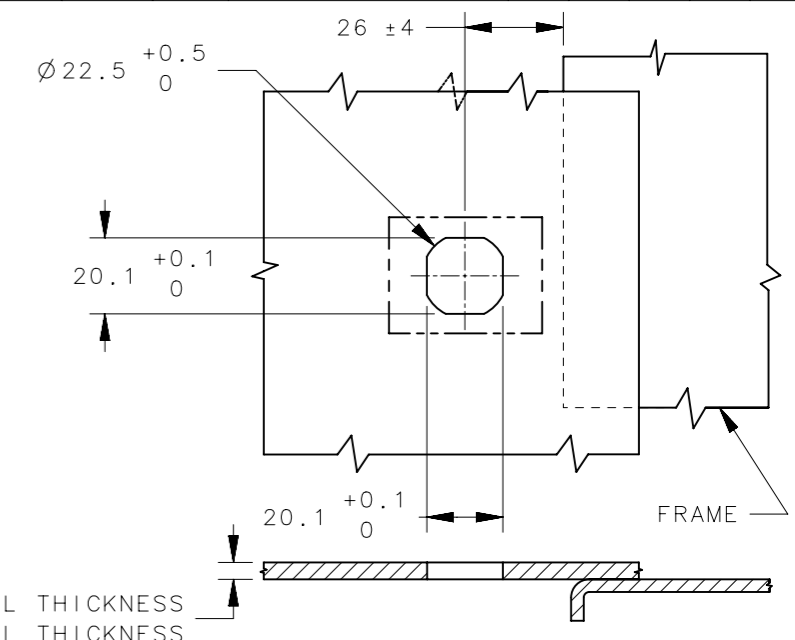
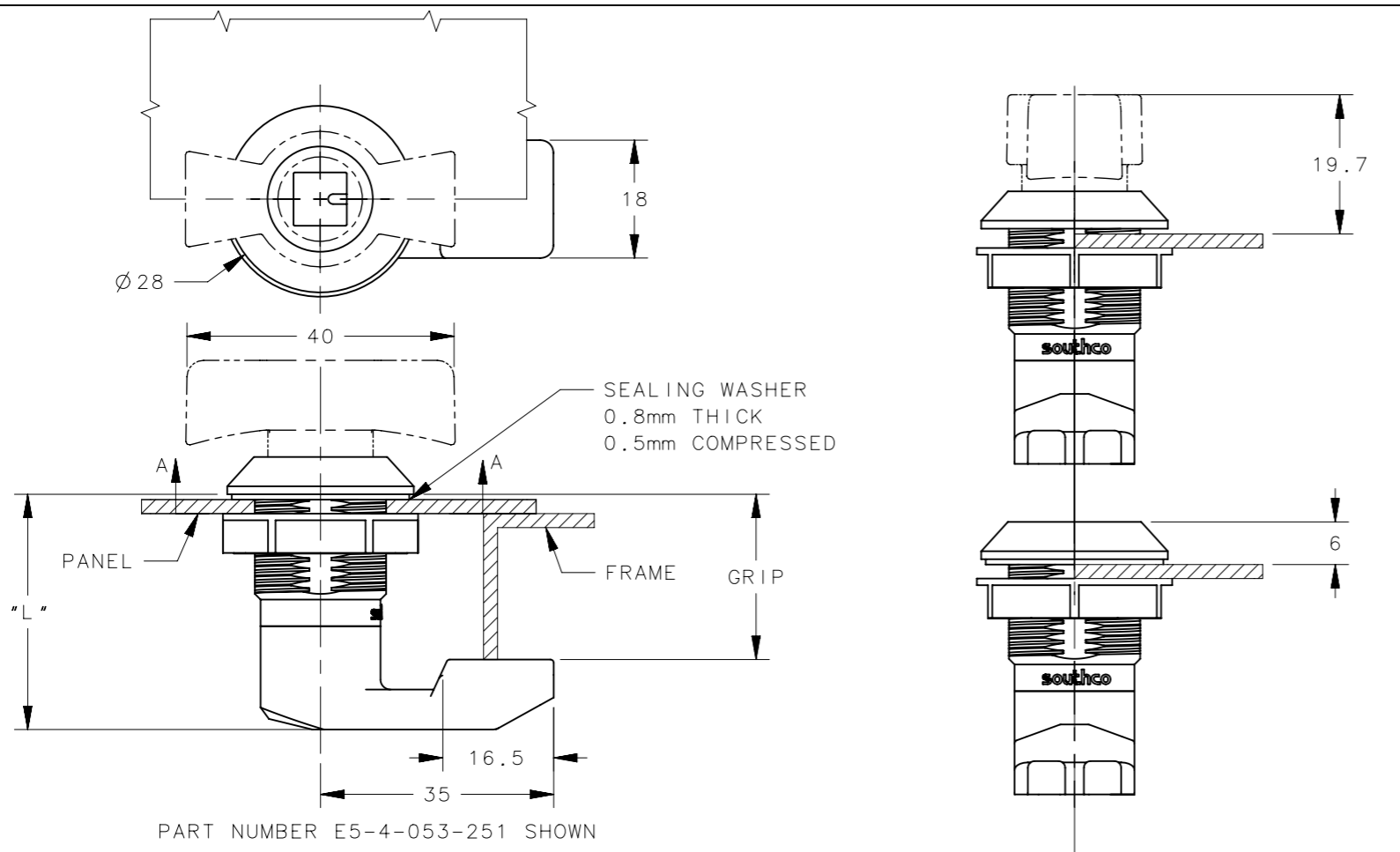

- NOTES:
- SEE SHEET 2 FOR INSTALLATION INSTRUCTIONS.
 - COSMETIC SPECIFICATION: ALL SURFACES ABOVE A-A CONFORM TO CLASS "C" DESIGNATION AS DESCRIBED IN SOUTHCO COSMETIC SPECIFICATIONS: S-121-04
 - MATERIAL AND FINISH:
 - A. HOUSING, DRIVE STUD, CAM AND MOUNTING NUT: GLASS FILLED NYLON BLACK.
 - B. CAM MOUNTING SCREW: STAINLESS STEEL, PASSIVATE.
 - C. SEALING WASHER: NITRILE RUBBER.
 - WHEN YY = 2 DIGITS, LATCH COMES WITH CAM PRE-ASSEMBLED. WHEN YY=UU, LATCH DOES NOT INCLUDE CAM. CAM TO BE ORDERED SEPARATELY. SEE CAM PART NUMBER CORRESPOND TO GRIP. SEE DRAWING J-E5-35.

SURFACE AREA VOLUME PROPRIETARY ITEM <small>EXCEPT FOR USES EXPRESSLY GRANTED IN WRITING, INFORMATION DISCLOSED HEREON IS CONFIDENTIAL AND ALL RIGHTS, PATENT AND OTHERWISE, ARE RESERVED BY SOUTHCO, INC.</small>	THIRD ANGLE PROJECTION	 CONNECT · CREATE · INNOVATE	
	MILLIMETERS [IN]		
	TOLERANCES UNLESS OTHERWISE NOTED	DESCRIPTION	
	ALL DIMENSIONS WITHOUT TOLERANCES ARE FOR REFERENCE ONLY.	E5 LATCH PLASTIC	
PER ASME Y14.5M-1994	SIZE A3	SYSTEM NX	DWG NO. J-E5-4
	DRAWN BY GKW/YGC	DATE 20FEB2015	SCALE 1:1 SHEET 1 OF 2

REVISION HISTORY			
REV	DATE	BY	DESCRIPTION
F	06NOV2019	DKP/DMS	PRN: P2019-2756

INSTALLATION METHOD 1

USE WHEN PANEL THICKNESS IS EQUAL TO OR LESS THAN MAXIMUM THICKNESS SHOWN IN GRIP TABLE.

1. PLACE SEALING WASHER ONTO LATCH HOUSING.
2. TILT LATCH THROUGH MOUNTING HOLE.
3. INSTALL MOUNTING NUT AND TIGHTEN TO: 4.25 N.m MAX.

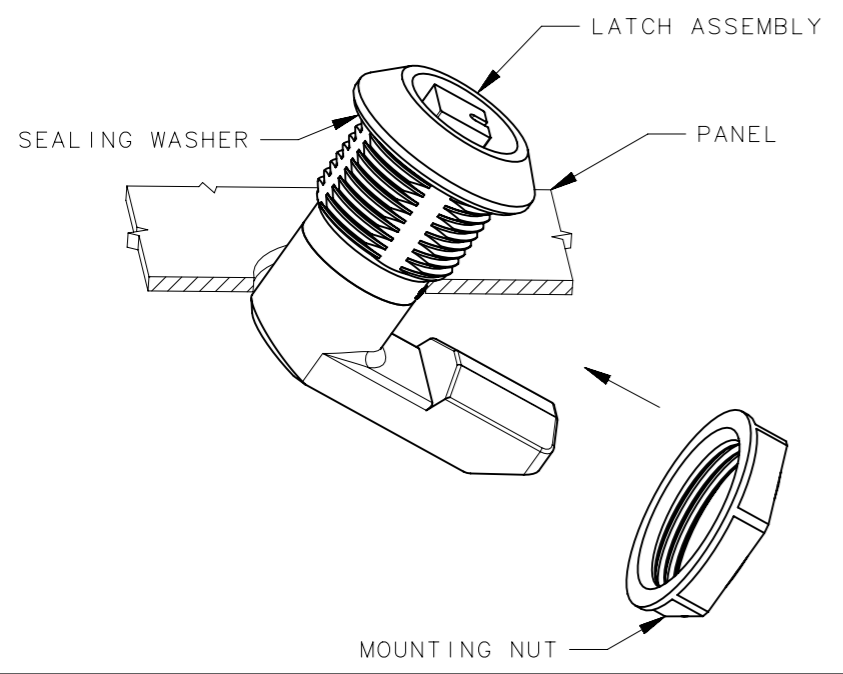

INSTALLATION METHOD 2

REQUIRED WHEN PANEL THICKNESS EXCEEDS MAXIMUM THICKNESS SHOWN IN GRIP TABLE OR WHEN CAM ORDERED SEPARATELY.

1. REMOVE SCREW FROM HOUSING, DETACHING CAM FROM LATCH ASSEMBLY. (WHEN CAM ORDERED ASSEMBLED)
2. PLACE SEALING WASHER ONTO LATCH HOUSING AND PLACE THROUGH MOUNTING HOLE.
3. INSTALL MOUNTING NUT AND TIGHTEN TO: 4.25 N.m MAX.
4. RE-ATTACH CAM TO LATCH ASSEMBLY. ENSURE CAM TIP POINTING TO PROPER ORIENTATION.
5. INSTALL SCREW AND TIGHTEN TO : 2 N.m.

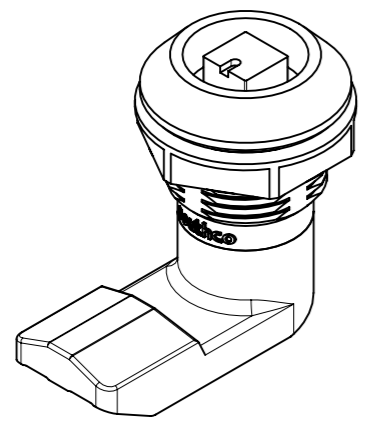
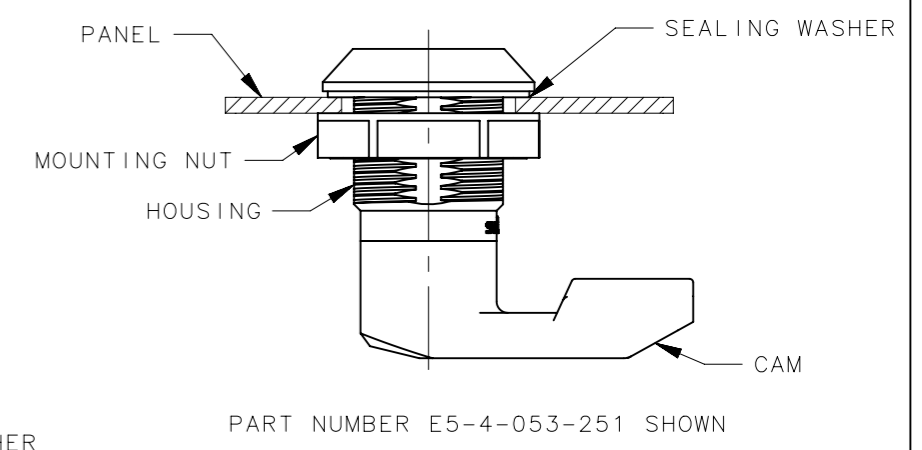
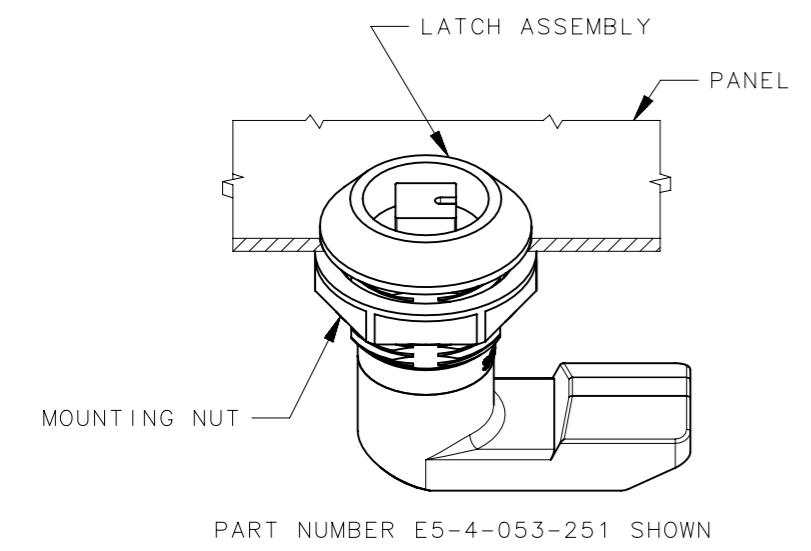
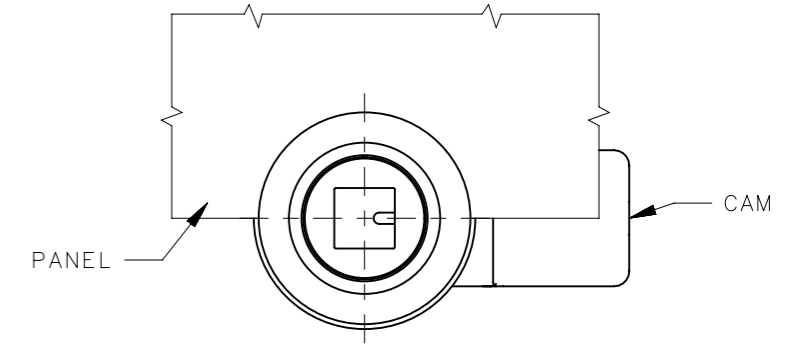
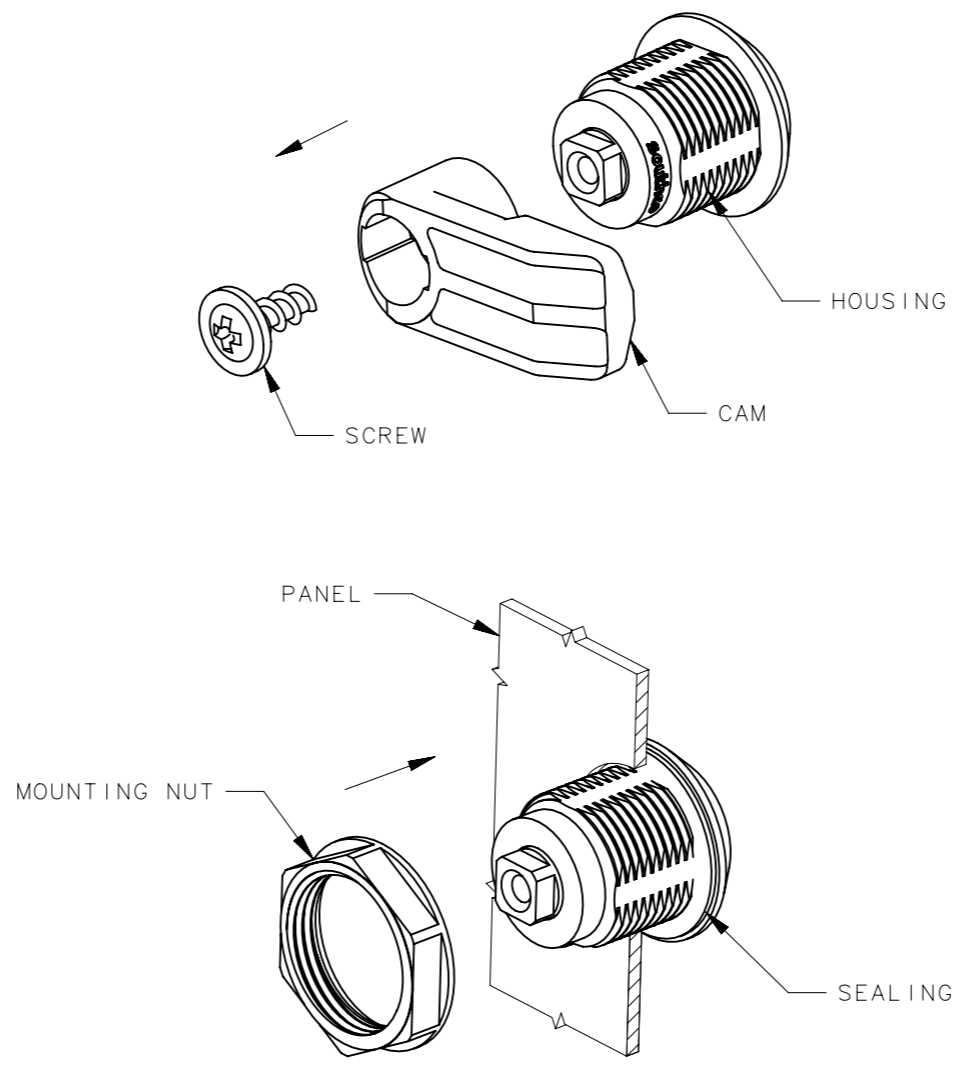

THIRD ANGLE PROJECTION		 CONNECT • CREATE • INNOVATE	
MILLIMETERS [IN]			
TOLERANCES UNLESS OTHERWISE NOTED		DESCRIPTION E5 LATCH PLASTIC	
ALL DIMENSIONS WITHOUT TOLERANCES ARE FOR REFERENCE ONLY.		SIZE A3	SYSTEM NX
PER ASME Y14.5M-1994		DWG NO. J-E5-4	DATE 20FEB2015
<small>PROPRIETARY ITEM EXCEPT FOR USES EXPRESSLY GRANTED IN WRITING, INFORMATION DISCLOSED HEREON IS CONFIDENTIAL AND ALL RIGHTS, PATENT AND OTHERWISE, ARE RESERVED BY SOUTHCO, INC.</small>		SCALE 1:1	SHEET 2 OF 2