

REVISION HISTORY			
REV	DATE	BY	DESCRIPTION
C	28JUN2012	BGL/TVA	PRN: P2012-0860

TORX® IS A REGISTERED TRADEMARK OF ACUMENT™ INTELLECTUAL PROPERTIES, LLC.

PART NUMBER 52-11-51-4-EEE SHOWN



SCALE 1:1

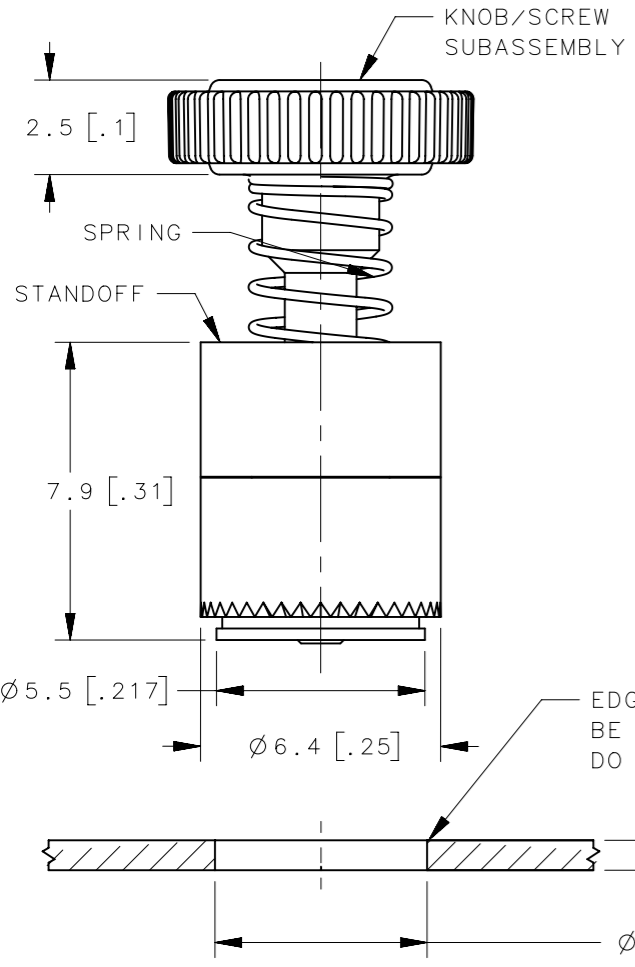
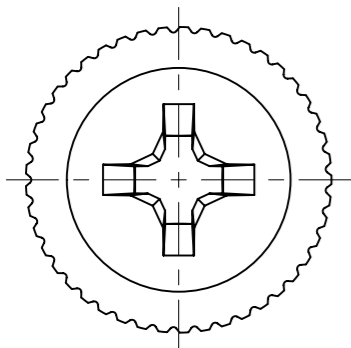

PANEL PREPARATION  $[\begin{smallmatrix} .219 \\ -0 \\ +.003 \end{smallmatrix}]$

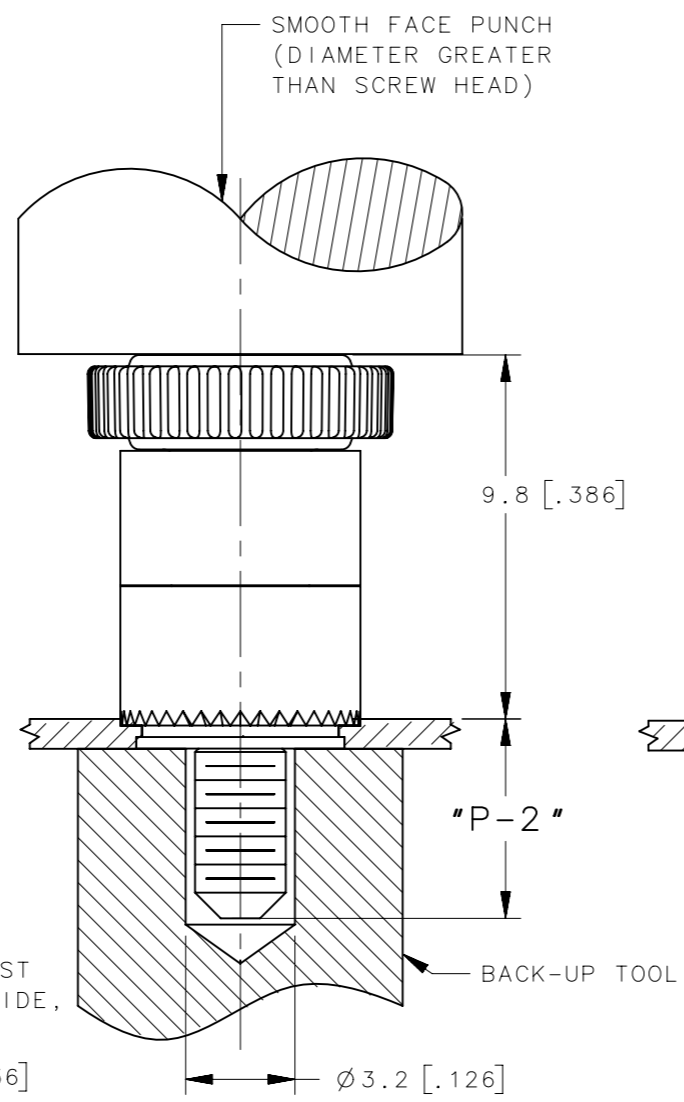

INSTALLATION (FASTENED)

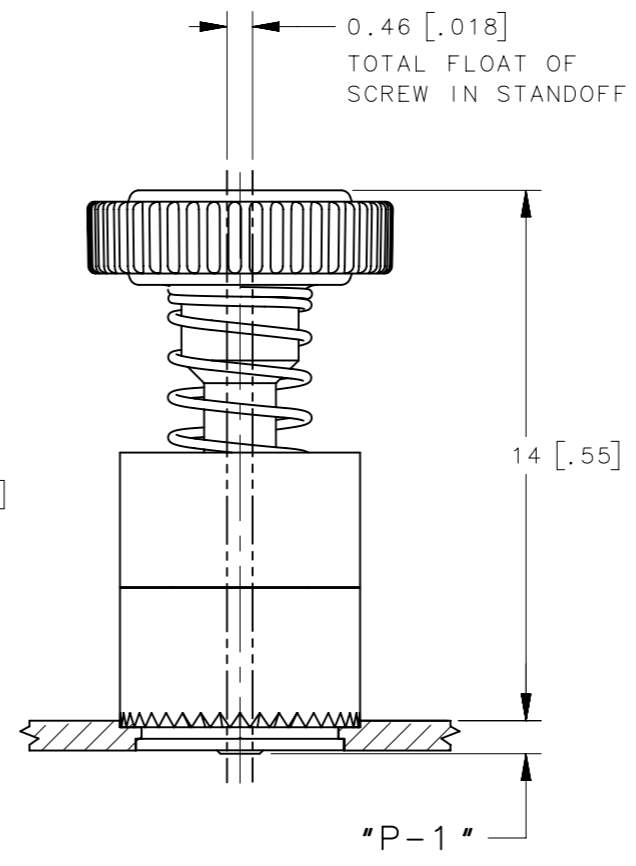

UNFASTENED

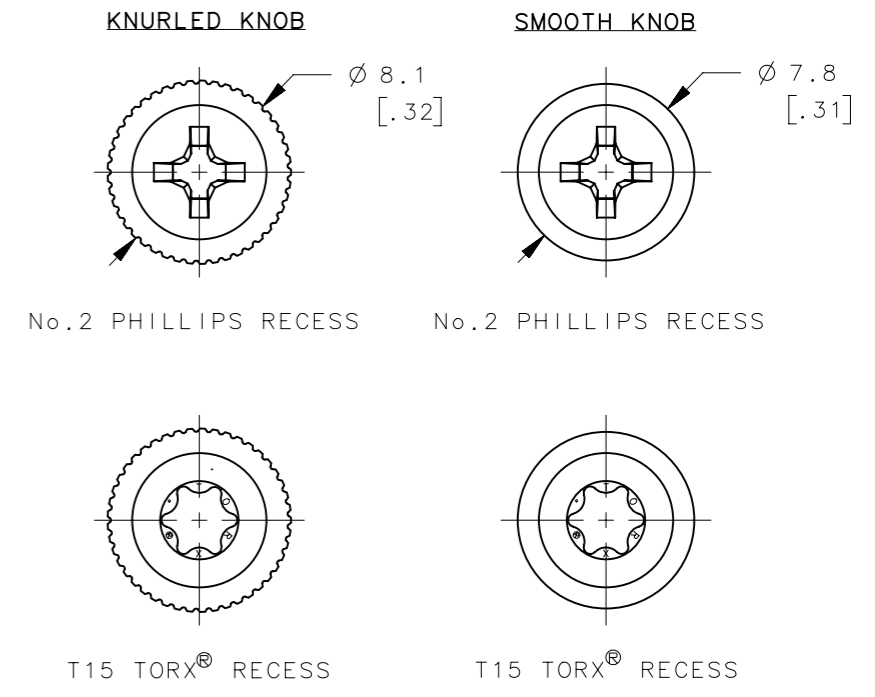

SCALE 3:1

- NOTES:
- A. MATERIAL AND FINISH: RoHS COMPLIANT  
 KNOB: PC/ABS UL94 V0 RATED, FLAME RETARDANT; TRIARYLPHOSPHATE (DOES NOT CONTAIN BROMINATED, CHLORINATED, OR HALOGENATED ADDITIVES).  
 SCREW: STEEL, HARDENED, ZINC PLATE PLUS SEALER  
 SPRING: 300 SERIES STAINLESS STEEL, PASSIVATED  
 STANDOFF: STEEL, ZINC PLATE, CHROMATE PLUS SEALER
  - B. INSTALLATION INSTRUCTIONS:
    1. PREPARE HOLE IN PANEL AS SHOWN OUTSIDE EDGE MUST BE SHARP; DO NOT CHAMFER.
    2. PUNCH SURFACE AND BACK-UP SURFACE MUST REMAIN PARALLEL DURING INSTALLATION. A HARDENED STEEL BACK-UP TOOL WITH A CLEARANCE HOLE AS SHOWN, IS RECOMMENDED.
    3. PRESS THE ASSEMBLY INTO THE PANEL UNTIL ONLY THE TOP OF THE KNURL ON THE STANDOFF IS VISIBLE. RECOMMENDED LOAD OF 5,500N FOR 5052-H32 ALUMINUM. RECOMMENDED LOAD OF 10,000N FOR STEEL,  $R_b \leq 60$  MAX.
  - C. RECOMMENDED MAXIMUM TORQUE OF 60 N-cm.
  - D. COSMETIC SPECIFICATION: ALL SURFACES (UNLESS OTHERWISE SPECIFIED) ARE TO BE PER SOUTHCO SPECIFICATION S-121-02 AND S-121-04, CLASS B (REFER TO SECTION 1.0 FOR CROSS REFERENCE TABLE).

**\*B\* SCREW RECESS AND KNOB STYLE**

- 1 - No.2 PHILLIPS RECESS, KNURLED KNOB
- 3 - No.2 PHILLIPS RECESS, SMOOTH KNOB
- 5 - T15 TORX® RECESS, KNURLED KNOB
- 6 - T15 TORX® RECESS, SMOOTH KNOB

**\*EEE\* KNOB COLOR**

SEE J-47-0-3 FOR DETAIL

52-1B-53-4-EEE	2.5 [.1]	6.8 [.27]
52-1B-51-4-EEE	0.91 [.036]	5.3 [.21]
PART NUMBER	*P-1*	*P-2*

THIRD ANGLE PROJECTION			
TOLERANCES UNLESS OTHERWISE NOTED	DESCRIPTION		
ALL DIMENSIONS WITHOUT TOLERANCES ARE FOR REFERENCE ONLY.	OVERMOLD 52 ASSEMBLY, 4-40 THREAD PRESS-IN STYLE		
PROPRIETARY ITEM	SIZE	SYSTEM	DWG NO.
EXCEPT FOR USES EXPRESSLY GRANTED IN WRITING, INFORMATION DISCLOSED HEREON IS CONFIDENTIAL AND ALL RIGHTS, PATENT AND OTHERWISE, ARE RESERVED BY SOUTHCO, INC.	A3	NX	J-52-3-440
PER ASME Y14.5M-1994	DRAWN BY	DATE	SCALE SHEET
	JQ/TVA	04MAR2011	5:1 1 OF 1