



NO. 2.5 LINK LOCK

DATE	DRAWN	CHK'D	SCALE	DRAWING NUMBER
28-SEP-92	pek		1:1	J-K4-2714

REV.	DATE	BY/CHK'D	REVISIONS
A	21MAY2001	CHW	DWG NO. WAS J-2-40-2714-07

OPTIONAL KEEPER PLATE
PART NO. K4-2338-07

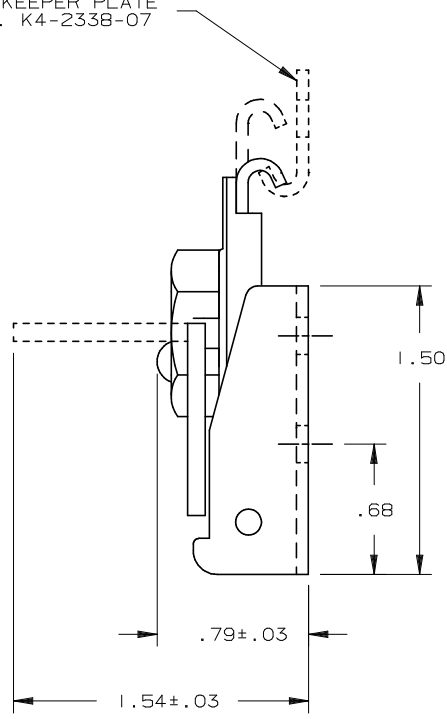
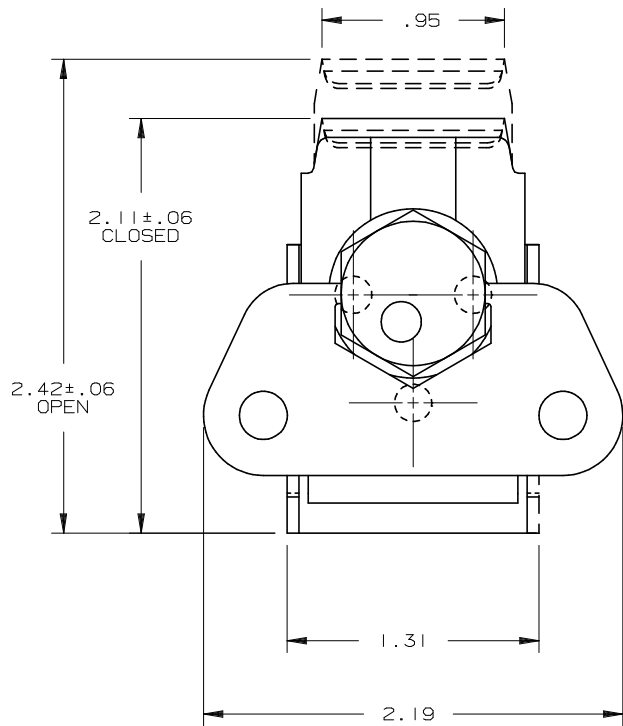

SUGGESTED PANEL PREPARATION

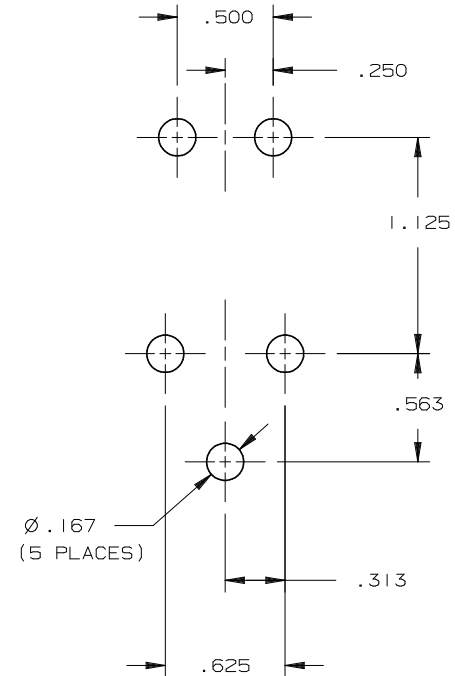

MATERIAL & FINISH:

ANCHOR PLATE, WING, HOUSING, LOWER CAM AND ANCHOR PLATE RIVET ARE CARBON STEEL; ZINC PLATE, BRIGHT CHROMATE DIP
SLIDE IS HARDENED ALLOY STEEL; ZINC PLATE, BRIGHT CHROMATE DIP
UPPER CAM IS POWDER METAL; ZINC PLATE, BRIGHT CHROMATE DIP
CAM RIVET AND CAM SPRING ARE STAINLESS STEEL.

PROPRIETARY ITEM - EXCEPT FOR USES EXPRESSLY GRANTED IN WRITING INFORMATION DISCLOSED HEREON IS CONFIDENTIAL AND ALL RIGHTS, PATENT AND OTHERWISE, ARE RESERVED BY SIMMONS FASTENER.

DIMENSIONS ARE IN INCHES

DECIMAL PLACES
2 PLACE (.XX)
3 PLACE (.XXX)

TOLERANCE
± 0.015
± 0.005

ALL ANGLES
± 1°

DRAWING NUMBER
J-K4-2714