

REVISION HISTORY			
REV	DATE	BY	DESCRIPTION
G	05JAN2018	RJV/MJS	PRN: P2018-0047

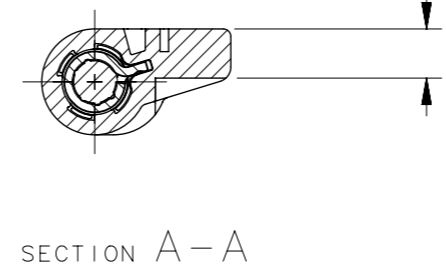

**TORQUE
(HOUSING STATIONARY)**

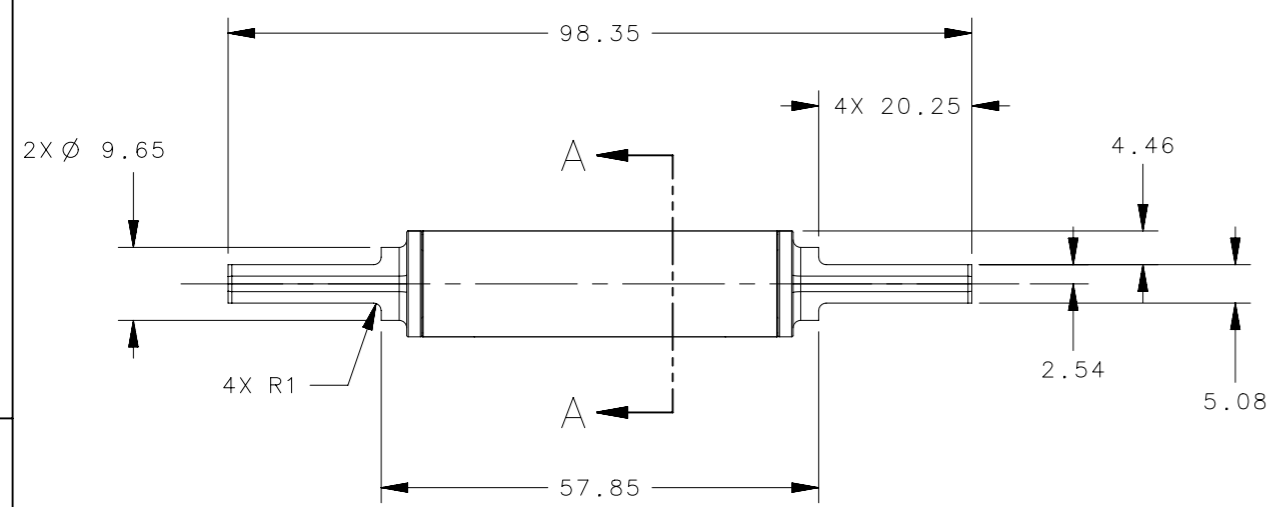
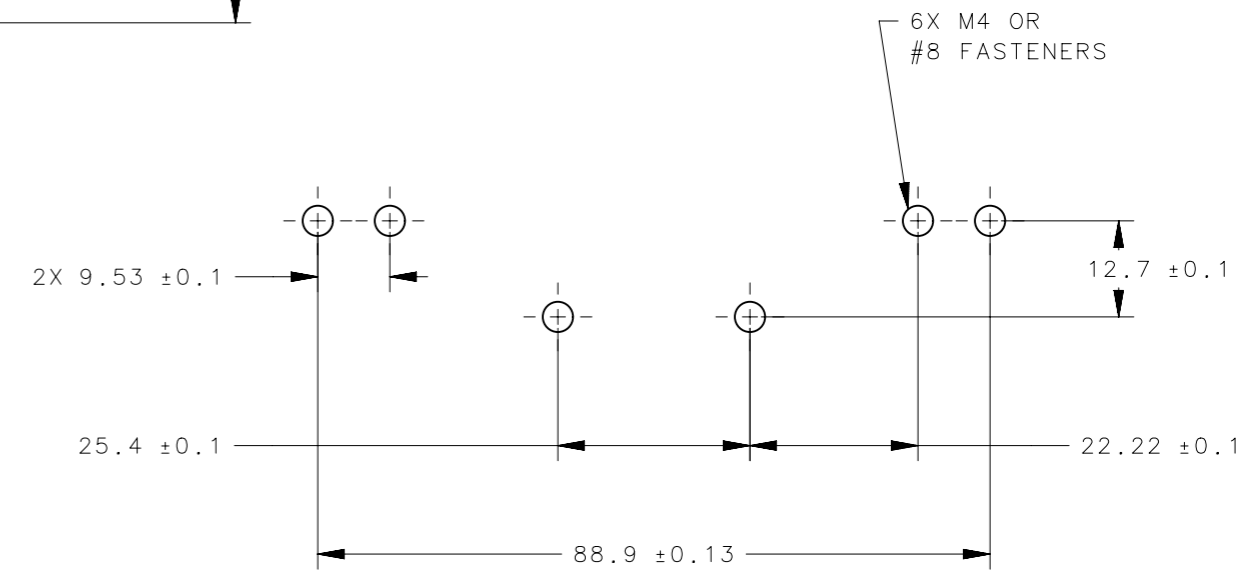
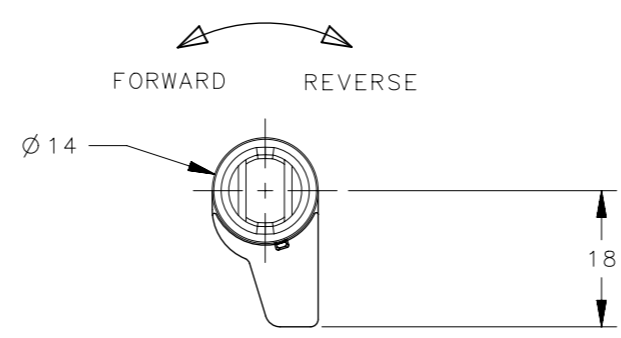
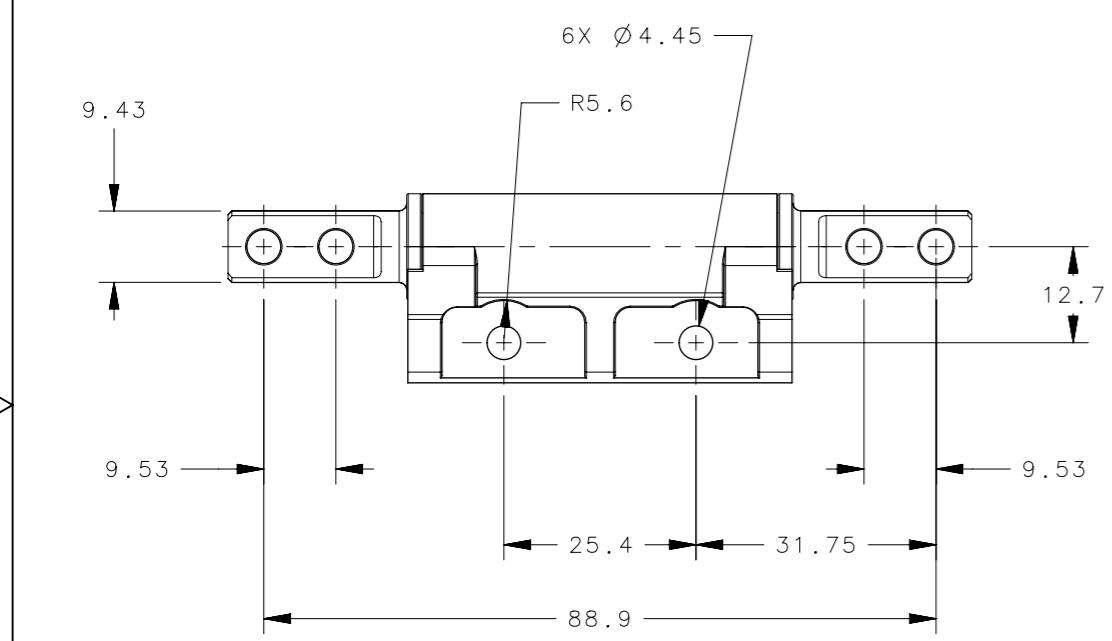
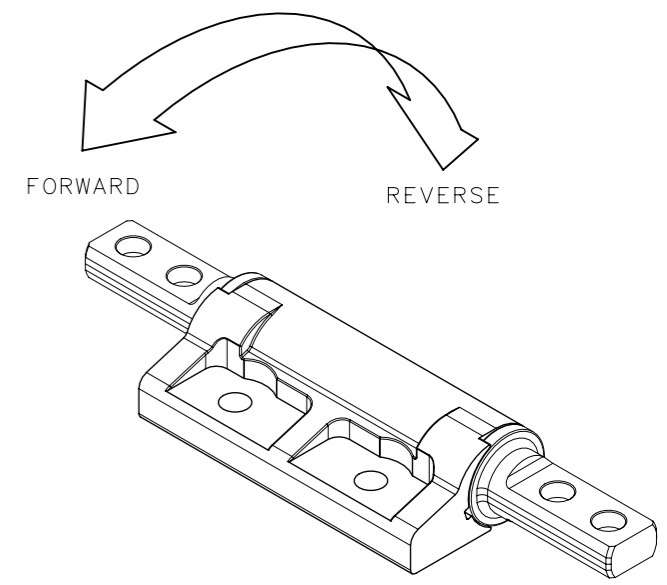

PANEL PREPARATION

- NOTES:
- MATERIAL AND FINISH:
HOUSING, ADAPTER AND END CAP - ZINC ALLOY
SHAFT AND TORQUE ELEMENTS - HARDENED STEEL
SLEEVES - ACETAL
LUBRICANT - HYDROCARBON BASE GREASE
 - INSTALL USING M4 SCREWS.
 - DIMENSIONS INDICATE AS-BUILT CONDITION.
ADAPTER TO ADAPTER SPACING WILL SELF ADJUST DURING OPERATION.
 - USE SIX FASTENERS FOR HINGE TORQUES FROM 3.16 N*m (28 in*lbf) TO 4.97 N*m (44 in*lbf).

PART NUMBER	STATIC TORQUE	
	FORWARD N*m (in-lbf)	REVERSE N*m (in-lbf)
TYPE H		
ST-10E-100SH-XX	1.13 (10)	1.13 (10)
ST-10E-120SH-XX	1.35 (12)	1.35 (12)
ST-10E-200SH-XX	2.26 (20)	2.26 (20)
ST-10E-280SH-XX	3.16 (28)	3.16 (28)
ST-10E-360SH-XX	4.06 (36)	4.06 (36)
ST-10E-200FH-XX	2.26 (20)	1.35 (12)
ST-10E-280FH-XX	3.16 (28)	1.89 (16.8)
ST-10E-360FH-XX	4.06 (36)	2.44 (21.6)
ST-10E-440FH-XX	4.97 (44)	2.93 (26)
ST-10E-200RH-XX	1.35 (12)	2.26 (20)
ST-10E-280RH-XX	1.89 (16.8)	3.16 (28)
ST-10E-360RH-XX	2.44 (21.6)	4.06 (36)
ST-10E-440RH-XX	2.93 (26)	4.97 (44)

TORQUE TOLERANCE ±20%

PART NUMBER	DESCRIPTION	FINISH
ST-10E-XXXXX-33	ASSEMBLY - "AS CAST"	NATURAL
ST-10E-XXXXX-50	ASSEMBLY - "COATED"	BLACK

THIRD ANGLE PROJECTION	
MILLIMETERS [IN]	
TOLERANCES UNLESS OTHERWISE NOTED	DESCRIPTION ST-10E-H HINGE ASSEMBLY
ALL DIMENSIONS WITHOUT TOLERANCES ARE FOR REFERENCE ONLY.	SIZE A3
PER ASME Y14.5M-1994	SYSTEM NX
	DWG NO. J-ST-10E-H
	DRAWN BY GEA
	DATE 06FEB2008
	SCALE 1:1
	SHEET 1 OF 1