

REVISION HISTORY			
REV	DATE	BY	DESCRIPTION
F	02MAR2021	CAB/LSS	PRN: P2021-0405

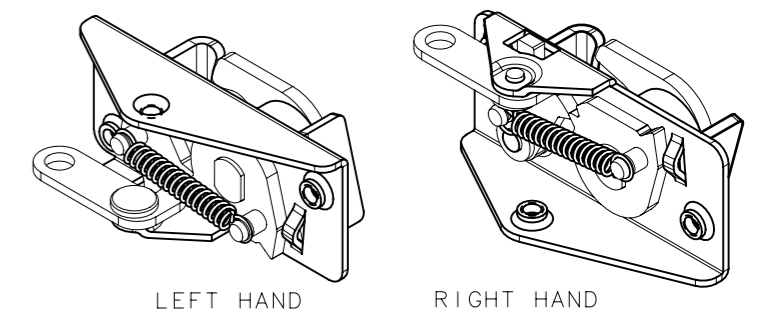

- NOTES:
- PART NUMBER R4-75-42-201-10 SHOWN.
 - MATERIAL AND FINISH:
 SPRING: STAINLESS STEEL
 OTHER COMPONENTS: CARBON STEEL, ZINC PLATED
 - INSTALLATION INSTRUCTIONS:
 - INSTALL STRIKER BOLT ASSEMBLY IN DOOR FRAME.
 - CLOSE DOOR CHECKING FOR INTERFERENCE OR MISALIGNMENT.
 - ADJUST STRIKER, ADD NECESSARY SHIM IF REQUIRED TO ACHIEVE PROPER POSITIONING OF STRIKER HEAD.
 - ADJUST STRIKER SO IT ENGAGES IN THE CENTER OF THE LATCH.
 - VERIFY THAT BOTH STAGES OF THE LATCH ARE FUNCTION PROPERLY.
 - CHECK DOOR ALIGNMENT AND SEAL PRESSURE.
 - THE TOLERANCE BETWEEN THE LATCH AND STRIKER BOLT ASSUMES A NON-RIGID DOOR INSTALLATION THAT WILL ALLOW THE DOOR TO MOVE INTO THE NOMINAL POSITION DURING LATCHING. RIGID DOORS MUST HAVE THE STRIKER INSTALLED PER THE PANEL PREPARATION RECOMMENDED.
 - THE MISALIGNMENT VIEW ASSUMES THE LATCH IS CONNECTED TO A PERFECTLY RIGID DOOR AND HINGE. THEREFORE, THERE IS NO DOOR AND/OR HINGE SLACK ASSOCIATED WITH THESE DIMENSIONS. THE MISALIGNMENT VIEW DOES NOT TAKE FLEXING OF THE STRIKER BOLT INTO ACCOUNT.
 - SEE SHEET 2 FOR MISALIGNMENT VIEW AND PANEL PREPARATION.

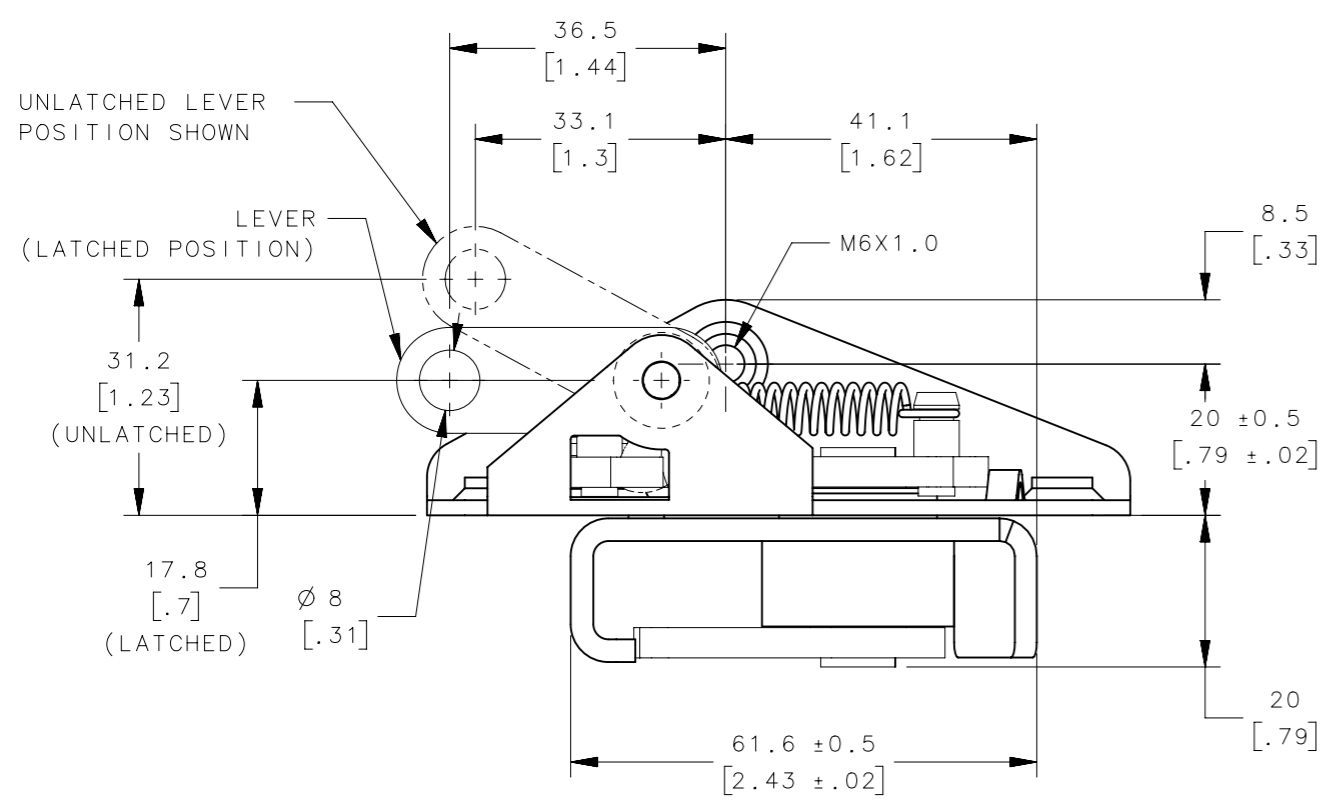
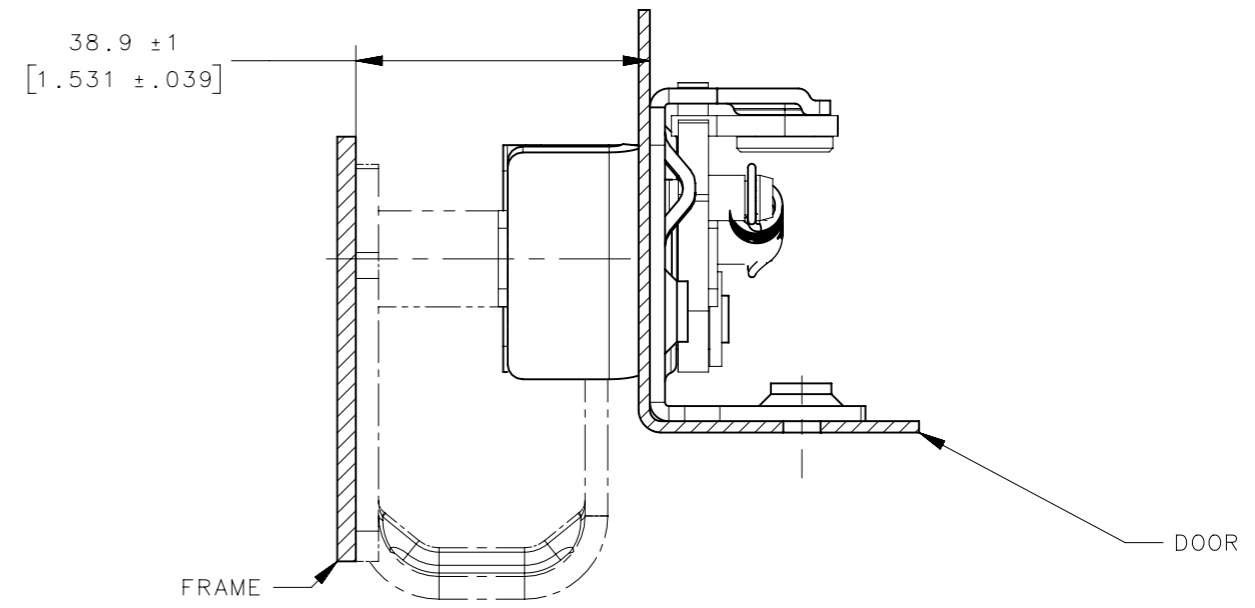
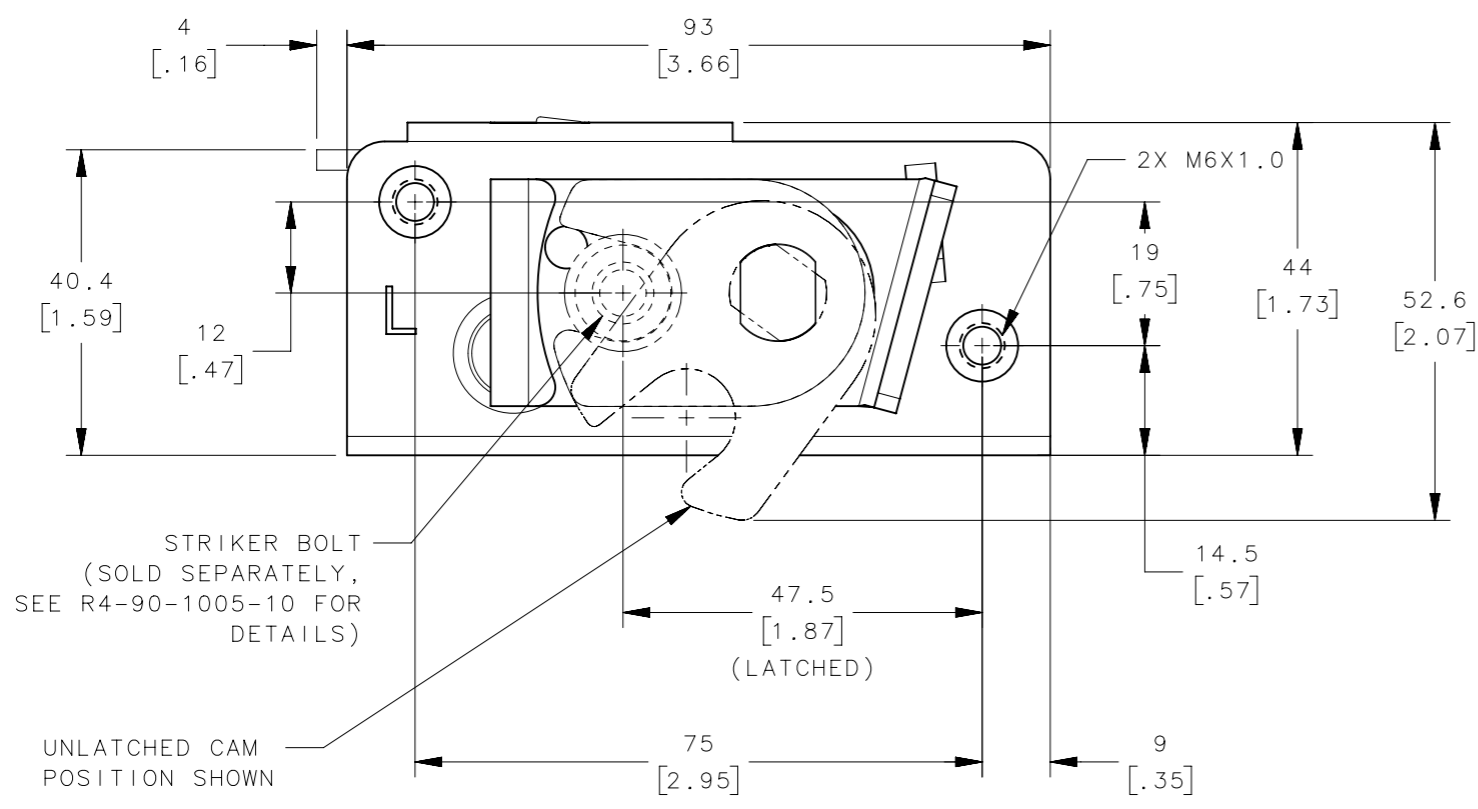

R4-75-42-203-10	ROTARY LATCH, LEFT HAND, WITH 1/8"-40 THREADED, ROD RETAINER
R4-75-32-203-10	ROTARY LATCH, RIGHT HAND, WITH 1/8"-40 THREADED, ROD RETAINER
R4-75-42-201-10	ROTARY LATCH, LEFT HAND
R4-75-32-201-10	ROTARY LATCH, RIGHT HAND
PART NUMBER	DESCRIPTION

CPB NUMBER 2017-0297	THIRD ANGLE PROJECTION	southco [®] CONNECT • CREATE • INNOVATE	
	MILLIMETERS [IN]		
SURFACE AREA mm ²	TOLERANCES UNLESS OTHERWISE NOTED	DESCRIPTION PUSH TO CLOSE LATCH	
VOLUME mm ³	ALL DIMENSIONS WITHOUT TOLERANCES ARE FOR REFERENCE ONLY.	SIZE A3	SYSTEM NX
PROPRIETARY ITEM EXCEPT FOR USES EXPRESSLY GRANTED IN WRITING, INFORMATION DISCLOSED HEREON IS CONFIDENTIAL AND ALL RIGHTS, PATENT AND OTHERWISE, ARE RESERVED BY SOUTHCO, INC.	PER ASME Y14.5M-1994	DWG NO. J-R4-75	DATE 17DEC2019
		DRAWN BY CAB/DM	SCALE 1:1
			SHEET 1 OF 2

REVISION HISTORY			
REV	DATE	BY	DESCRIPTION
F	02MAR2021	CAB/LSS	PRN: P2021-0405

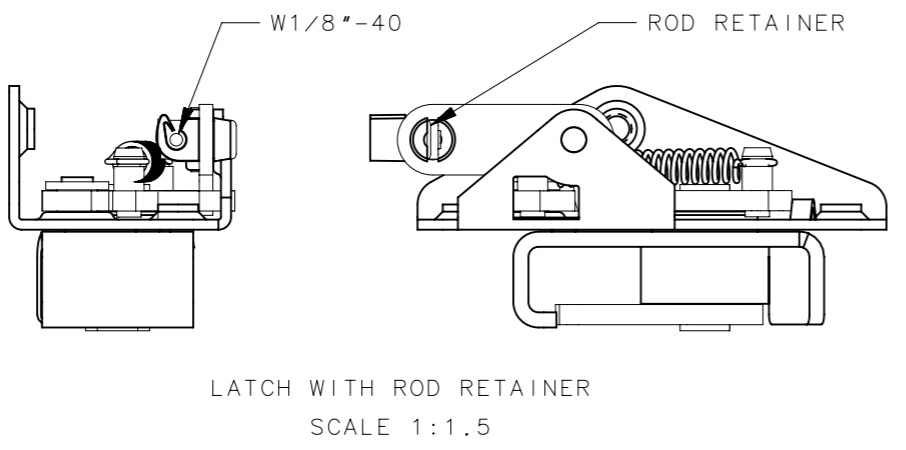
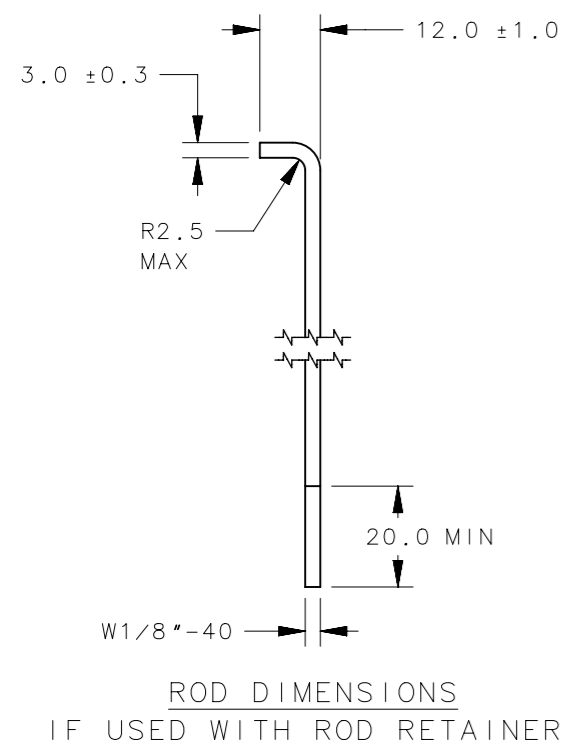
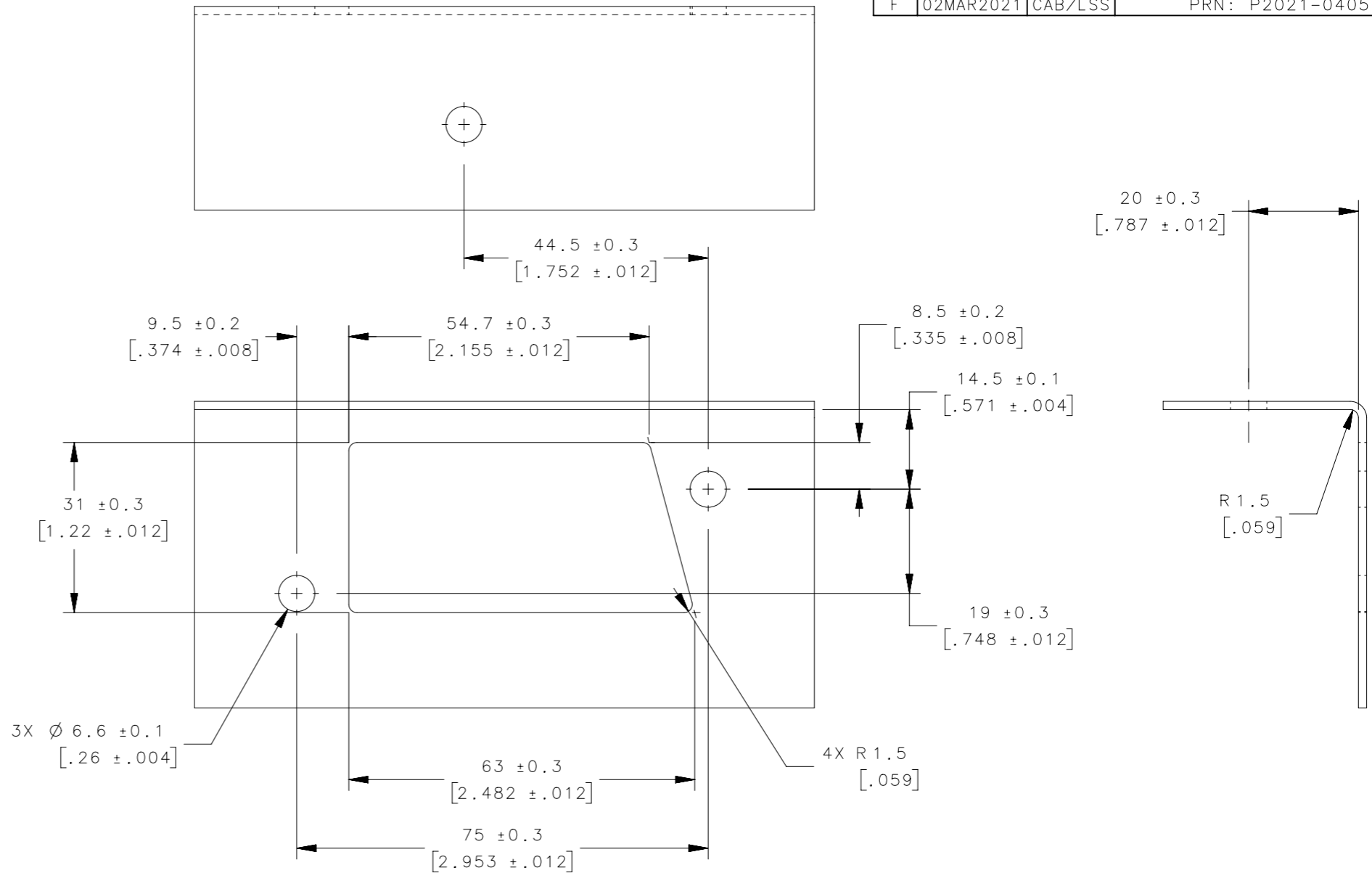
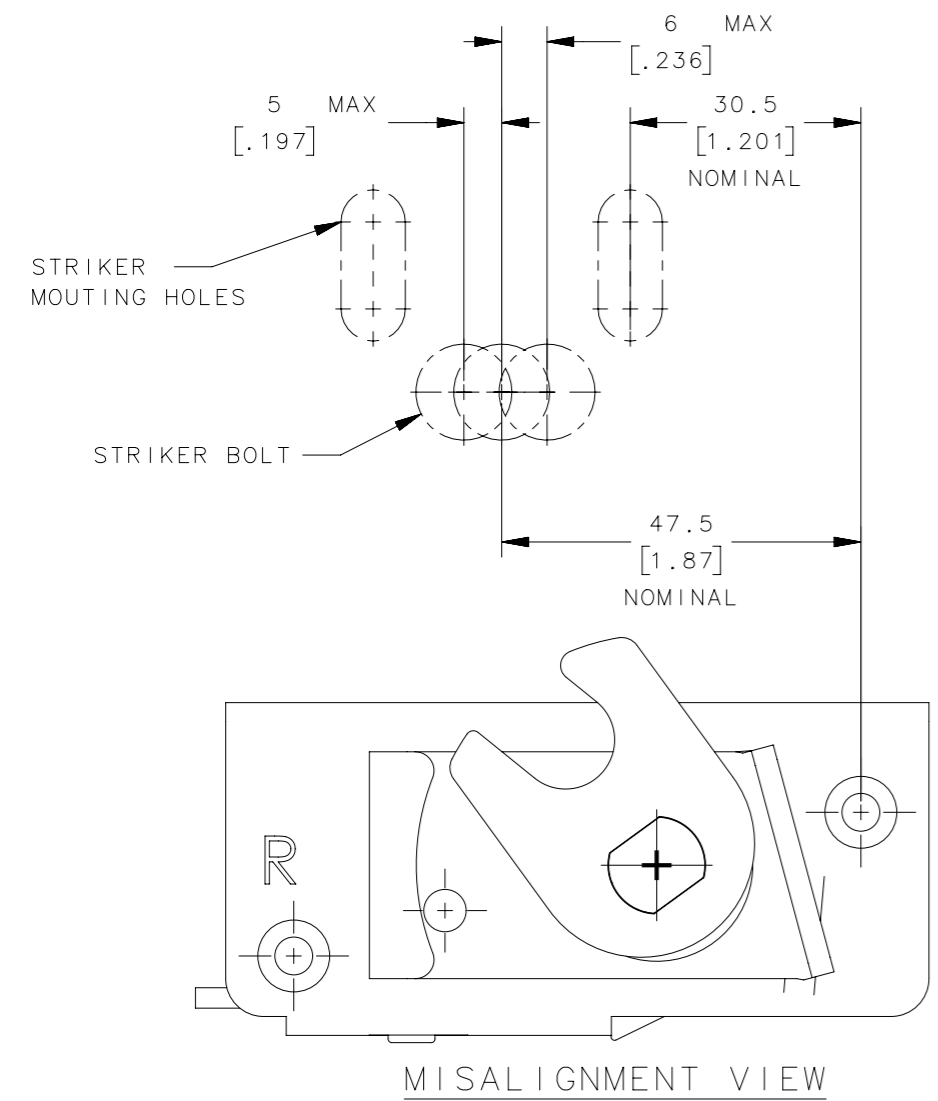

CPB NUMBER 2017-0297	THIRD ANGLE PROJECTION	southco [®] CONNECT • CREATE • INNOVATE	
	MILLIMETERS [IN]		
SURFACE AREA mm ²	TOLERANCES UNLESS OTHERWISE NOTED	DESCRIPTION PUSH TO CLOSE LATCH	
VOLUME mm ³	ALL DIMENSIONS WITHOUT TOLERANCES ARE FOR REFERENCE ONLY.	SIZE A3	SYSTEM NX
PROPRIETARY ITEM EXCEPT FOR USES EXPRESSLY GRANTED IN WRITING, INFORMATION DISCLOSED HEREON IS CONFIDENTIAL AND ALL RIGHTS, PATENT AND OTHERWISE, ARE RESERVED BY SOUTHCO, INC.	PER ASME Y14.5M-1994	DWG NO. J-R4-75	DATE 17DEC2019
		DRAWN BY CAB/DM	SCALE 1:1
			SHEET 2 OF 2