

NOTES:

A. COSMETIC SPECIFICATION:

DESIGNATED SURFACES ARE TO CONFORM TO THE CLASS CALLED OUT AS DESCRIBED IN SOUTHCO COSMETIC SPECIFICATIONS:

- S-121-01 FOR CHROME PLATING
- S-121-03 FOR POWDER COATING

B. MATERIAL AND FINISH:

-LEVER, HANDLE, AND HOUSING: DIE-CAST ZINC;
 CHROME FINISH: BRIGHT CHROME PLATED
 BLACK FINISH: BLACK POWDER COATED

-ADJUSTING SCREW, JAM NUTS, MOUNTING BRACKET,
 AND MOUNTING SCREW: STEEL; ZINC PLATED

-SPRING: STAINLESS STEEL

-GASKET: BLACK RUBBER

-LOCKWASHER: STEEL; ZINC PLATED

-LOCK PLUG: DIE CAST ZINC WITH STAINLESS STEEL
 COVER, BRASS WAFERS

C. LOCKS ARE TO BE KEYED ALIKE PER CH751 CODE USING
 FIVE TUMBLER WAFERS. TWO KEYS ON RING, SUPPLIED.

D. LATCH IS SHOWN IN UNLOCKED POSITION.



southco

PROPRIETARY ITEM - EXCEPT FOR USES EXPRESSLY
 GRANTED IN WRITING, INFORMATION DISCLOSED
 HEREON IS CONFIDENTIAL AND ALL RIGHTS PATENT
 AND OTHERWISE ARE RESERVED BY SOUTHCO, INC.

**C5 SMALL SEALED LEVER LATCH
 LOCKING AND NON-LOCKING**

DATE: 24JUN2005
 DRAWN: AAB
 CHKD: AJH
 SCALE: 1:1

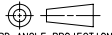
DRAWING NUMBER:
J-C5-M-1

REV	DATE	DRAWN/CHKD	DESCRIPTION	MATERIAL & FINISH SEE NOTE B			PART NUMBERS				MILLIMETERS
A	04AUG2005	CSC/MDY	PRN: P2005-1003	GRIP	A	B	BLACK		CHROME		ALL DIMENSIONS WITHOUT TOLERANCES ARE FOR REFERENCE ONLY.
B	12SEP2005	MDY/MJS	PRN: P2005-1211				NON-LOCKING	LOCKING WITH SHUTTER	NON-LOCKING	LOCKING WITH SHUTTER	
C	01FEB2007	VNK/VPR	PRN: P2007-0172	1 - 25	36.5	13.5	C5-M-11-15	C5-M-31-15	C5-M-11-112	C5-M-31-112	 THIRD ANGLE PROJECTION  A3 PAPER SIZE
				15 - 30	40	28.5	C5-M-11-25	C5-M-31-25	C5-M-11-212	C5-M-31-212	

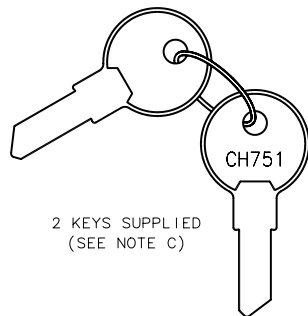

2 KEYS SUPPLIED
 (SEE NOTE C)

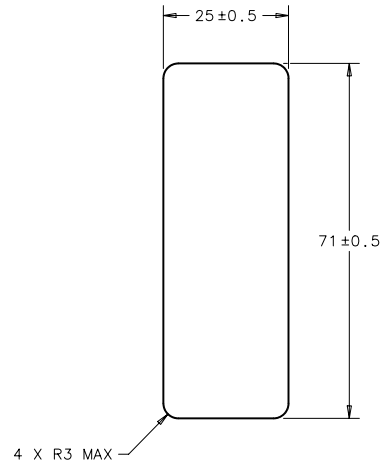
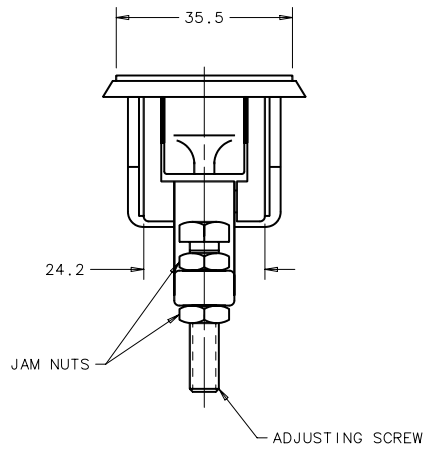
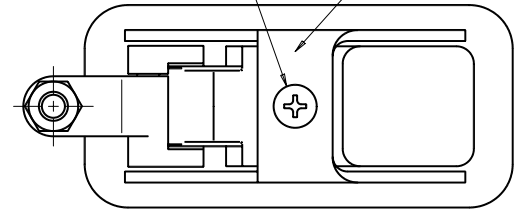
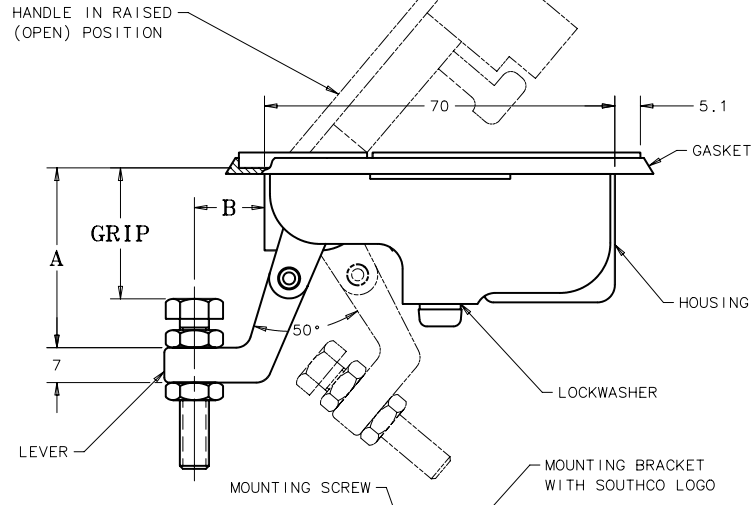
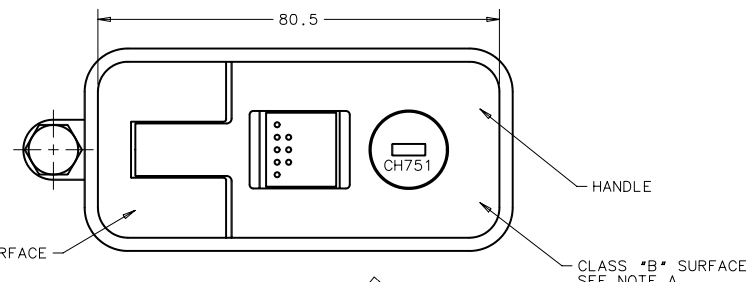

PANEL PREPARATION

(P/N C5-M-31-1X SHOWN)