

REVISION HISTORY			
REV	DATE	BY	DESCRIPTION
0	10AUG2022	CMS/CTG	PRN: P2022-1428

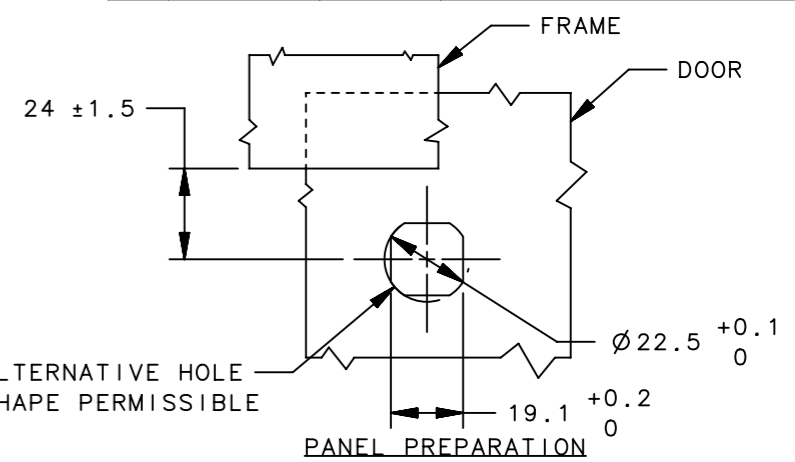
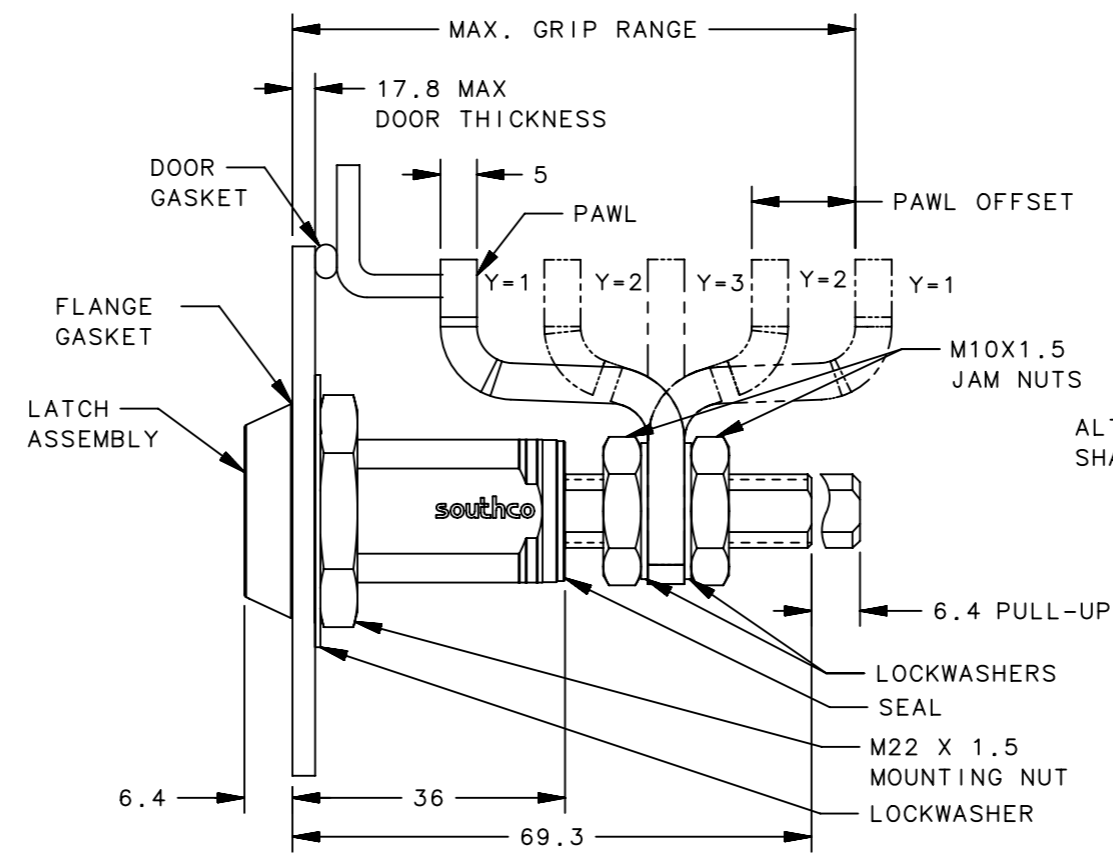
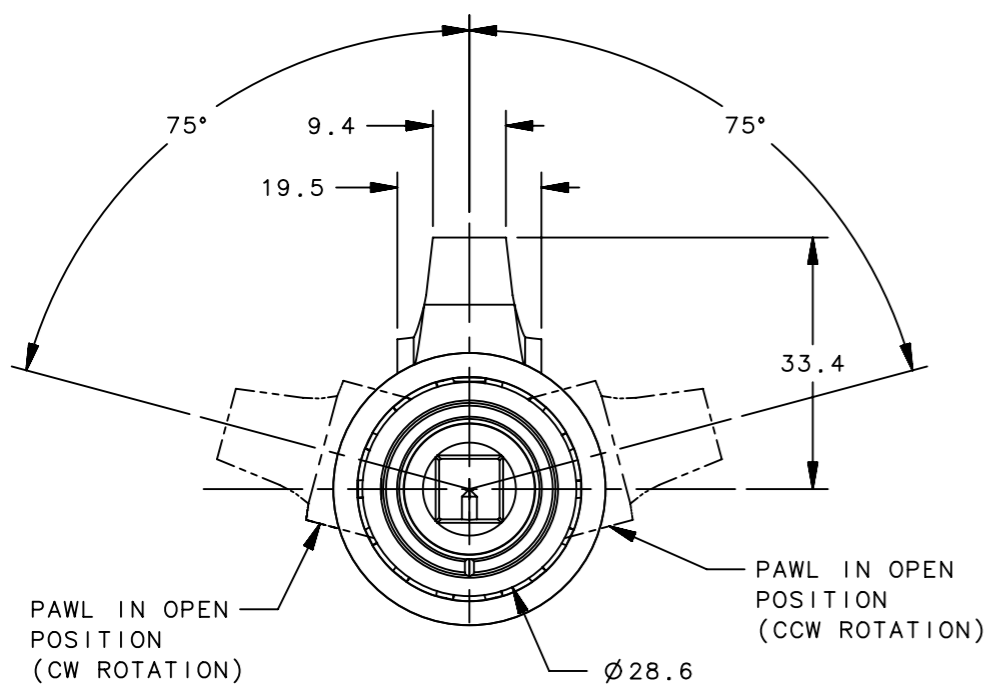

DRIVER	KEY PART NUMBER
3mm DOUBLE-BIT	E3-2-1
7mm TRIANGLE	E3-3-1
7mm SQUARE	E3-4-1
TUBULAR KEY	E3-5-15
8mm HEX RECESS	NOT SUPPLIED BY SOUTHCO
BELLCORE 216	E3-12-1
3mm SLOTTED RECESS	NOT SUPPLIED BY SOUTHCO
8mm SQUARE	E3-8-1
RAILWAY STANDARD	E3-14-1

KEYS TO BE ORDERED SEPARATELY

NOTES :

- A. OPERATION: 195° TURN OF KEY CAUSES PAWL TO ROTATE 75° THEN PULL UP 6.4mm.
- B. PAWL, NUTS AND LOCKWASHERS SHIPPED UNASSEMBLED IN BAG WITH LATCH ASSEMBLY.
- C. INSTALLATION:
 1. INSERT LATCH INTO HOLE IN DOOR. CHECK FOR PROPER ORIENTATION AND OPERATION WITH PAWL.
 2. INSTALL USING LOCKWASHERS AND MOUNTING NUT(27mm ACROSS FLATS). MAXIMUM TIGHTENING TORQUE 20Nm.
 3. INSTALL JAM NUT, LOCKWASHER, PAWL, LOCKWASHER AND JAM NUT ON SHAFT. ADJUST JAM NUTS TO POSITION PAWL AT CORRECT GRIP (WITH LATCH CLOSED). TIGHTEN JAM NUTS (20Nm MAX. TORQUE) USING TWO 17mm WRENCHES.
- D. CAUTION: ADJUST PAWL SO THAT NO MORE THAN 7.9Nm TORQUE IS REQUIRED TO CLOSE THE LATCH.

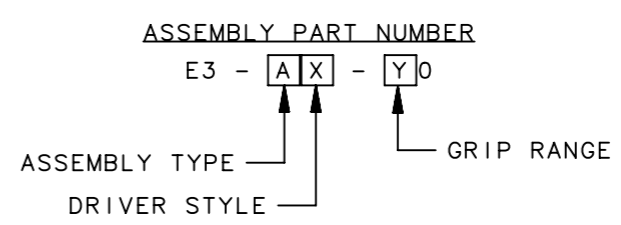

GRIP RANGE	MINIMUM GRIP	MAXIMUM GRIP
Y=1	16.4	32.2
Y=2	30.4	46.1
Y=3	43.9	59.6
Y=2	57.6	73.3
Y=1	71.3	81.2

DRIVER (X)

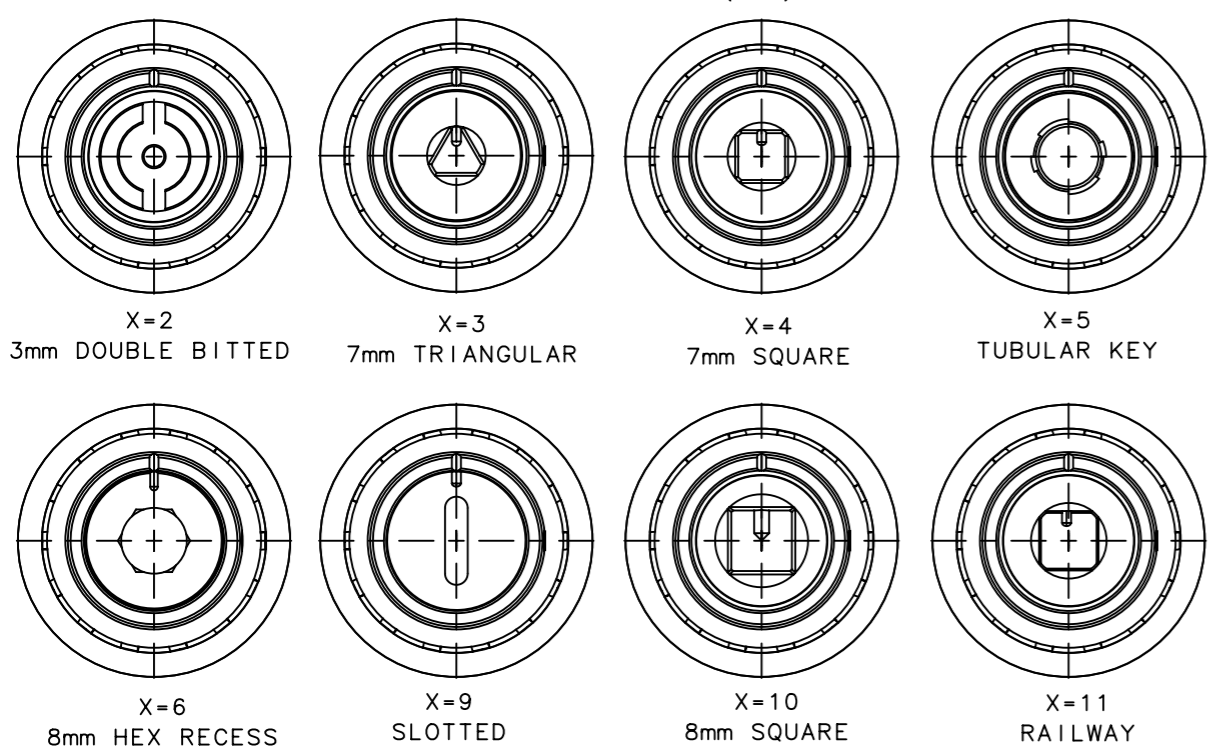

ASSEMBLY TYPE	ROTATION
1	CW
22	CCW

16	-	1	SEAL	BUNA - N	NATURAL
15	-	1	GASKET SEAL	NEOPRENE	NATURAL
14	-	1	JAM NUT	304/316 STAINLESS STEEL	PASSIVATED
13	-	1	LOCKWASHER	304/316 STAINLESS STEEL	PASSIVATED
12	-	1	MOUNTING NUT	STAINLESS STEEL	NATURAL
11	-	1	PAWL	304 STAINLESS STEEL	PASSIVATED
10	-	1	PIN	1008 STEEL	ZINC PLATE WITH CHROMATE DIP
9	-	1	SHAFT	304/316 STAINLESS STEEL	PASSIVATED
8	-	1	CAM	1075 STEEL	ZINC FLAKE COATING
7	-	1	SLEEVE	304 STAINLESS STEEL	PASSIVATED
6	-	1	O-RING	BUNA - N	NATURAL
5	-	1	SPRING	302 STAINLESS STEEL	NATURAL
4	-	1	RETAINER	302 STAINLESS STEEL	BLACK OXIDE
3	-	1	BUSHING	304/316 STAINLESS STEEL	PASSIVATED
2	-	1	CAP	304/316 STAINLESS STEEL	PASSIVATED
1	-	1	HOUSING	304/316 STAINLESS STEEL	PASSIVATED
-	E3-AX-Y0	-	LATCH ASSEMBLY	-	-
NO.	PART NUMBER	QTY.	TYPE OF COMPONENT	MATERIAL	FINISH

CPB NUMBER

THIRD ANGLE PROJECTION

MILLIMETERS [IN]

SURFACE AREA

VOLUME

PROPRIETARY ITEM

EXCEPT FOR USES EXPRESSLY GRANTED IN WRITING, INFORMATION DISCLOSED HEREON IS CONFIDENTIAL AND ALL RIGHTS, PATENT AND OTHERWISE, ARE RESERVED BY SOUTHCO, INC.

PER ASME Y14.5M-1994

DESCRIPTION: STAINLESS STEEL E3 LATCH VICE ACTION SERIES, LARGE SIZE

SIZE: A3 SYSTEM: NX DWG NO.: J-E3-100

DRAWN BY: LJC DATE: 14MAY2001 SCALE: 1:1 SHEET: 1 OF 1

southco
CONNECT · CREATE · INNOVATE