



PROPRIETARY ITEM - EXCEPT FOR USES EXPRESSLY GRANTED IN WRITING INFORMATION DISCLOSED HEREON, IS CONFIDENTIAL AND ALL RIGHTS PATENT AND OTHERWISE ARE RESERVED BY SOUTHCO, INC.

E3 VISE ACTION™ COMPRESSION LATCH ASSEMBLY SINGLE HOLE MOUNT, SMALL SIZE, STAINLESS STEEL

DATE: 03SEP2004  
DRAWN: AAB  
CHKD: MJS  
SCALE: NTS

DRAWING NUMBER: TD-E3-04-J  
PAPER SIZE: A

REV	DATE	DRAWN/CHKD	DESCRIPTION
B	02MAY2017	CMS/ILT	PRN: P2017-1017
C	14FEB2023	CMS/JC	PRN: P2023-0287

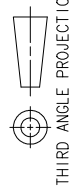

SOUTHCO PERFORMANCE GUIDELINES  
THE PERFORMANCE GUIDELINES SHOWN ON THIS PAGE ARE SUPPLIED AS A GENERAL GUIDE ONLY, AS CONDITIONS VARY WITH EACH APPLICATION AND METHOD OF INSTALLATION. STRENGTH DATA GIVEN IS FOR FAILURE OF THE PRODUCT OR FOR SUFFICIENT DEFORMATION TO MAKE PRODUCT INOPERABLE. NO SAFETY FACTOR HAS BEEN APPLIED. IT IS RECOMMENDED THAT THE USER REQUEST A PRODUCT SAMPLE FOR TESTING TO DETERMINE THE SUITABILITY OF THE PRODUCT FOR THE PURPOSE INTENDED AND USER'S PARTICULAR APPLICATION.

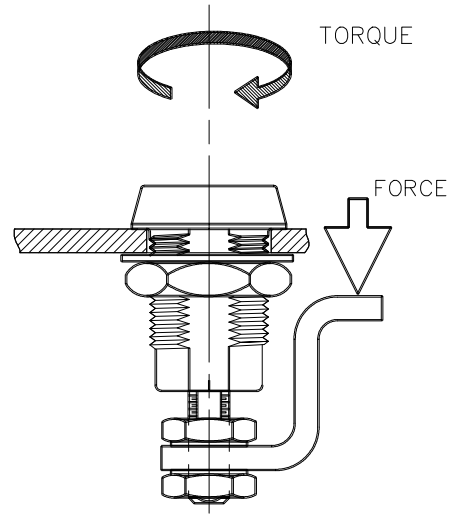

PART NO.	THREAD TYPE
E3-55-X2	METRIC
E3-56-X2	METRIC
E3-57-X2	METRIC
E3-59-X2	METRIC

COMPRESSIVE STRENGTH - Suggested WORKING FORCE ①: 356 N / 80 LBS  
Average ULTIMATE FORCE ②: 778 N / 175 LBS

OPERATION TORQUE LIMITS - To develop a compressive force on the pawl of 330 N/75 lbs, an operating torque of 3.2 N-m/ 28.8 in.-lbs was required to lock the fastener. ③

RECOMMENDED TIGHTENING TORQUE - MOUNTING NUT: 13 N-m (115 in-lbf)  
PAWL MOUNTING NUT: 5 N-m (44 in-lbf)

- ① WORKING FORCE is the maximum force that the product will withstand without affecting the operation or appearance of the product.
- ② Average ULTIMATE FORCE causes failure of the product or sufficient deformation to make the product inoperable.
- ③ Overloading the fastener beyond these conditions is not recommended.